

| | | | | | | |
|---|--------------------------------|-------|----|--|--|--|
|  | TECHNICAL SPECIFICATION | | No | I-ET-0600.00-5510-760-PPT-601 | | |
| | BUYER: | | | SRGE | | SHEET: |
| | PROGRAM: | | | FLOATING PRODUCTION UNITS - BOT | | 1 of 54 |
| | AREA: | | | SRGE / ESUP / PIES | | SCALE: |
| TIC/TIC-OI | | TITLE | | | | TELECOM MASTER SPECIFICATIONS FOR BOT UNITS |

INDEX OF REVISIONS

| REV. | DESCRIPTION AND/OR AFFECTED SHEETS |
|------|------------------------------------|
| 0 | ORIGINAL |

| | REV. 0 | REV. A | REV. B | REV. C | REV. D | REV. E | REV. F | REV. G | REV. H |
|--------------|-------------|--------|--------|--------|--------|--------|--------|--------|--------|
| DATE | Jul/14/2024 | | | | | | | | |
| DESIGN | PROJ-US | | | | | | | | |
| EXECUTION | ROBSON | | | | | | | | |
| VERIFICATION | CHRISTIANO | | | | | | | | |
| APPROVAL | JOMAR | | | | | | | | |

THE DATA, OR PARTS THEREOF, ARE BUYER PROPERTY AND SHALL NOT BE USED IN ANY WAY WITHOUT THEIR PERMISSION.
THIS FORM IS IN ACCORDANCE WITH BUYER STANDARD N-381 – REV. F



I N D E X

| | | |
|-------|---|----|
| 1. | OBJECTIVE..... | 3 |
| 2. | REFERENCE..... | 3 |
| 3. | DEFINITIONS | 3 |
| 4. | GMDSS SYSTEM | 4 |
| 5. | OPERATIONAL RADIO SYSTEM..... | 4 |
| 6. | ETEX CLASS M | 6 |
| 7. | UHF ACTIVE REPEATER SYSTEM | 8 |
| 8. | PUBLIC ADDRESS AND GENERAL ALARM SYSTEM | 9 |
| 9. | IPTV SYSTEM | 12 |
| 10. | UHF TV SYSTEM | 13 |
| 11. | TELEPHONE SYSTEM | 13 |
| 12. | INDUSTRIAL TELEPHONE SYSTEM..... | 14 |
| 13. | STRUCTURED VOICE AND DATA NETWORKS..... | 15 |
| 14. | DATA EQUIPMENT..... | 17 |
| 15. | BUYER SERVERS | 23 |
| 16. | PI INTERCONNECTION..... | 28 |
| 16.1. | FIREWALL..... | 28 |
| 16.2. | DMZ SWITCH | 29 |
| 17. | INMARSAT | 29 |
| 18. | BUYER WIRELESS LAN – WLAN..... | 30 |
| 19. | BUYER TELECOMMUNICATION ROOM | 31 |
| 20. | TELECOMMUNICATIONS RACKS | 32 |
| 21. | VIDEOCONFERENCE SYSTEM | 34 |
| 22. | VSAT SYSTEM..... | 36 |
| 23. | VSAT SYSTEM FOR THE SELLER OPERATION PERIOD | 37 |
| 24. | LEO (LOW EARTH ORBIT) SATELLITE | 37 |
| 25. | DC POWER SYSTEM..... | 38 |
| 26. | INFRASTRUCTURE FOR SUBMARINE FIBER OPTIC NETWORK..... | 39 |
| 27. | RADIO ROOM | 41 |
| 28. | COMPUTERS AND PRINTERS | 41 |
| 29. | INTERNET CAFE | 42 |
| 30. | CCTV SYSTEM | 43 |
| 31. | TOOLS AND INSTRUMENTS | 47 |
| 32. | CABLES | 49 |
| 33. | TELECOM SHUTDOWN SYSTEM..... | 49 |
| 34. | LTE (LONG TERM EVOLUTION) SYSTEM..... | 50 |
| 35. | ANTENNAS | 50 |
| 36. | SELLER TELECOMMUNICATION SYSTEM..... | 51 |
| 37. | DETAILED DESIGN DOCUMENTATION..... | 51 |
| 38. | CRANE TELECOMMUNICATIONS REQUIRMENTS | 52 |
| 39. | TELECOM TOWER | 52 |
| 40. | E-POB SYSTEM..... | 52 |
| 41. | TEMPORARY INTERNET SERVICE..... | 53 |

1. OBJECTIVE

- 1.1. To present the Telecommunications Systems requirements demanded by BUYER for the Telecommunications Systems to be supplied, installed, configured and commissioning by SELLER at BOT unit.

2. REFERENCE

- 2.1. The Telecommunications systems and equipment shall comply with applicable standards specifications and Flag Administration requirements.
- 2.2. SELLER shall be responsible for filling all necessary documents for ANATEL and CINDACTA licenses for operation in Brazil.
- 2.3. All telecommunication equipment installed in outdoor areas, that must remain powered on after ESD-3, shall be certified for Zone 2, Gr IIB, T4, conform IEC 60079-14.

3. DEFINITIONS

| | | | |
|--------|--|--------|---|
| AC | Alternating Current | ITU | International Telecommunication Union |
| AHTS | Anchor Handling Tug Supply | KVA | Kilo Volt Ampere |
| AM | Amplitude Modulation | LAN | Local Area Network |
| ANATEL | Agencia Nacional de Telecomunicações (Brazilian Telecommunication Authority) | LED | Light Emitting Diode |
| ANSI | American National Standards Institute | LNB | Low Noise Block Converter |
| EIA | Electronic Industries Alliance | LSZH | Low Smoke Zero Halogen |
| TIA | Telecommunications Industry Association | MODU | Mobile Offshore Drilling Unit |
| ART | Anotação De Responsabilidade Técnica (Technical Responsibility Note) | MOSCAD | Motorola Supervisory Control And Data Acquisition |
| AWG | American Wire Gauge | NDB | Non Directional Beacon |
| BUC | Block up Converter | NOC | Network Operation Center |
| CAB | Cable | NTSC | National Television Systems Committee |
| CAT | Category | ODU | Outdoor Data Unit |
| CATV | Community Antenna Television | OMTS | Offloading Monitoring Telemetry System |
| CCR | Central Control Room | PAGA | Public Address And General Alarm |
| CCTV | Closed Circuit Television | PAL-M | Phase Alternate Line Type M |
| CODEC | Codifier & Decodifier | PI | Plant Information |
| CREA | Conselho Regional de Arquitetura e Urbanismo (Brazilian Engineering Counsel) | PLL | Phase Locked Loop |
| DC | Direct Current | PoE | Power Over Ethernet |
| DIO | Dispositivo Intrmediário Óptico (Optical Distribution Drawer) | PP | Patch Panel |
| DSV | Diving Support Vessel | PSV | Platform Supply Vessel |
| DVD | Digital Versatile Disc | ROIP | Radio over IP |
| EEX | European Energy Exchange | SC | Subscription Channel Connector |
| ENV | Environmental | SFP | Small Form-Factor Pluggable |
| ETEX | Estações de Telecomunicações Exclusivas (Air Traffic Controller) | MM | Multi Mode |
| ETH | Ethernet | SMA | Serviço Móvel Aeronáutico (Aeronautical Mobile Service) |
| FM | Frequency Modulation | SMM | Serviço Móvel Marítimo (Maritime Mobile Service) |
| FO | Fiber Optic | SOLAS | Safety Of Life At Sea |
| GMDSS | Global Maritime Distress Safety System | SPL | Sound Pressure Level |
| GPS | Global Positioning System | TVRO | Television Read Only |
| HDPE | High Density Polyethylene | UHF | Ultra Highband Frequency |
| HDX | High Definition "X" Experience | UPS | Uninterruptible Power Supply |
| ICA | Instruções do Comando da Aeronáutica (Aeronautical Brazilian Authority) | FTP | Unshielded Twisted Pair |
| IDU | Indoor Data Unit | VAC | Volts Alternating Current |
| IMO | International Maritime Organization | VDC | Volts Direct Current |
| IP | Internet Protocol | VMS | Visual Monitoring System |
| IS | Intrinsec Safe | VHF | Very High Frequency |
| | | VSAT | Very Small Aperture Terminal |
| | | WAN | Wide Area Network |

4. GMDSS SYSTEM

- 4.1. Global Maritime Distress and Safety System shall follow all requirements regulated by IMO/SOLAS and Classification Society about International Distress and Safety System.
- 4.2. The Unit shall comply with all the GMDSS requirements for operation in sea area A3, including AIS radio.
- 4.3. The AIS equipment shall have one LAN interface (RJ-45) in order to be interconnected to BUYER LAN network. Additionally, it shall be supply 01 (one) port RS-232 Serial device server, manufactured by Advantech MODEL EKI-1522. The IP address to be configured will be informed by BUYER later.
- 4.4. The GMDSS equipment shall be mounted in a console in the Radio Room.
- 4.5. It shall comply with at least two maintenance methods required in item 1.6 of HARMONIZATION OF GMDSS REQUIREMENTS FOR RADIO INSTALLATIONS ON BOARD SOLAS SHIPS.
- 4.6. The GMDSS detailed design shall be approved by Classification Society.

5. OPERATIONAL RADIO SYSTEM

- 5.1. The Radio Communication System shall allow operational communication with supply vessels, other Units and with Brazilian Telecommunication Coastal Station.
- 5.2. A **VHF/FM-SMM Network (Mobile Maritime System)** to allow communication with other platforms and vessels, with the minimum requirements described below:
 - a. 01 (one) non DSC VHF maritime base station, limited to a maximum of 6W, in Radio Room (beside the GMDSS console);
 - b. 02 (two) non DSC VHF maritime base stations, limited to a maximum of 6W, in Central Control Room (CCR);
 - c. 01 (one) non DSC VHF maritime base station in Logistic Technical Office;
 - d. 01 (one) non DSC VHF maritime base station at COEMB (Vessel Coordinator) workstation;
 - e. All VHF maritime base stations shall be powered by UPS;
 - f. 24 (twenty four) VHF maritime portable radios, each radio with, display, IS (Intrinsically Safe), remote speaker microphone, spare battery, single charger and carry case, configured with all ITU international channels plan.
 - g. The radios, batteries and all accessories shall be suitable for operation in zone 1 hazardous areas in an outdoor tropical marine environment.
 - h. 02 (two) six-way battery charger for portable radios;
 - i. All radio equipment supplied shall be homologated by ANATEL.
 - j. SELLER shall be responsible for issue all documents to legalize the system according to Brazilian legislation.

5.3. VHF SYSTEM - REMOTE ACCESS

- 5.3.1. The VHF system shall have a remote access facility based on MOTOROLA SmartPPT solution for dispatch from BUYER onshore Remote Control Room;



- 5.3.2. The MOTOROLA SmartPPT solution shall be able to connect and access the offshore VHF radios using the IP network.
- 5.3.3. It shall be provided one dedicated server to be installed at the FPSO to run the MOTOROLA SmartPPT software package.
- 5.3.4. It shall be provided and installed all licenses, for the Brazilian region, for perform the connection with existing BUYER SmartPPT system, to stablish an VHF radio communication from Remote Control Room located in BUYER onshore base station.
- 5.3.4.1. Including the Audio Reception Level License for the portable radios.
- 5.3.4.2. Including the onshore server license (to be informed by BUYER during the detailed design)
- 5.3.5. The licenses necessities for the Remote Control Room shall also be provided together with the VHF system.
- 5.4. An **UHF Network (Production and Maintenance Service)** to allow internal communication between utility, process plant or any other area of the Unit, with the minimum requirements described below:
- 01 (one) UHF base station in Radio Room;
 - 03 (three) UHF base stations in Central Control Room;
 - 01 (one) UHF base station in the EAR – Electric and Automation room;
 - 01 (one) UHF base station in Operator's room located in topside;
 - All UHF base stations shall be powered by UPS;
 - 100 (a hundred) portable IS UHF radios with IS remote speaker microphone, spare battery, charger and carry case.
 - The radios, batteries and all accessories shall be suitable for operation in zone 1 hazardous areas in an outdoor tropical marine environment.
 - The minimum operating frequency range of the UHF transceivers shall be from 450 to 470 MHz, with a minimum of 12 (twelve) channels available for programming.
 - 04 (four) six-way battery charger for portable radios.
 - The UHF frequency plan will be advised by BUYER during the detailed design.
 - All radio equipment supplied shall be homologated by ANATEL.
 - SELLER shall be responsible for issuing all documents in order to legalize the system according to Brazilian legislation.
 - All UHF radios shall use digital modulation technology (DMR) in order to comply with ANATEL Resolution 558/2010.
 - It shall be supplied a Programming Kit and software for all base station and portable radios for using in the maintenance and programming of UHF Radios during the unit operation.
- 5.5. An appropriate **operational radio console** shall be installed in the Radio Room, beside the GMDSS console. The Radio Communication System shall comprise the following equipment:
- VHF maritime base radio (according to item 5.2.a);
 - UHF radio (according to item 5.4.a);
 - 02 (two) VHF/AM-SMA radios (according to item 6.1.1);
 - Public Address Access Panel;

6. ETEX CLASS M

The ETEX Class M shall enable operational communication between the Unit and helicopters and air navigation aid. It shall be in accordance with the requirements stated in the last revision ICA 63-10, ICA 63-25 and NORMAM-27/DPC.

6.1. Radio Equipment

- 6.1.1 It shall be provided 02 (two) VHF/AM-SMA base stations to allow communication between the Unit and helicopters. Both radios shall be installed in the radio communication console in the Radio Room.
- 6.1.1.1 Both VHF/AM-SMA base stations radios shall have the frequency locked in the frequency designated by Brazilian Air Force department.
- 6.1.1.2 Both radios shall have audio output interface in order to interconnect with the voice record system
- 6.1.2 It shall be provided 02 (two) hand-portable radio-transceivers VHF/AM-SMA for use in the helideck, with appropriate headphone.
- 6.1.3 All radio equipment supplied shall be homologated by ANATEL.
- 6.1.4 SELLER shall be responsible for issuing all documents to legalize the ETEX Class M according to Brazilian legislation.
- 6.1.5 According to ICA 63-25/2010, it shall be provided and installed a voice record system for VHF/AM-SMA base station.
- 6.1.6 It shall be supplied a Programming Kit and software for all base station and portable radios for using in the maintenance and programming during the unit operation.

6.2. Helideck Monitoring System

- 6.2.1 It shall be provided a Helideck Monitoring System adequate for ETEX (Telecommunications and Air Traffic Station Permission) Class M, according to the requirements stated in the ICA 63-10 from the Brazilian Aviation Authority and NORMAN-27 from Brazilian Navy Authority, such as:
- a. Wind speed and direction sensor;
 - b. Relative humidity sensor;
 - c. Barometric pressure sensor;
 - d. Air temperature sensor;
 - e. Pitch, roll and yaw sensors.
- 6.2.2 These systems shall be automatic and this information shall be available on a display in the Radio Room.
- 6.2.3 It will be acceptable a display from ENV System installed in the radio room.
- 6.2.4 The meteorological and positioning sensors shall be installed in adequate place without obstruction or another element that could interfere in their reading.
- 6.2.5 Helideck motion monitoring system shall be able to monitor helideck heave, heave velocity, roll, pitch and inclination in real-time.

6.3 INTEGRATED AUDIO AND VIDEO RECORDING SYSTEM

It shall be supplied and installed an integrated audio and video recording system comply with the Brazilian regulations ICA 63-10, ICA 63-25 and NORMAM-27/DPC, following the requirements below:

6.3.1 Audio Recording requirements

6.3.1.1 It shall be provided and installed a voice recorder system, in order to record and store all communications made by the VHF/AM-SMA base station, portable radio VHF/AM-SMA and the Helicopters during the Helideck operation.

6.3.1.2 The audio recorder shall have the following requirements:

- a. Audio recordings shall be automatic during any Aeronautical VHF communications;
- b. Be recorded on a dedicated device onboard;
- c. Recorded audio shall be intelligible;
- d. System shall have redundancy of hard disks to store files;
- e. Recorded audio shall be stored for at least 03 months and be able to be retrieved.

6.3.2 Video Recording requirements

6.3.2.1 It shall be installed an exclusive CCTV cameras to monitor and record the helideck operations.

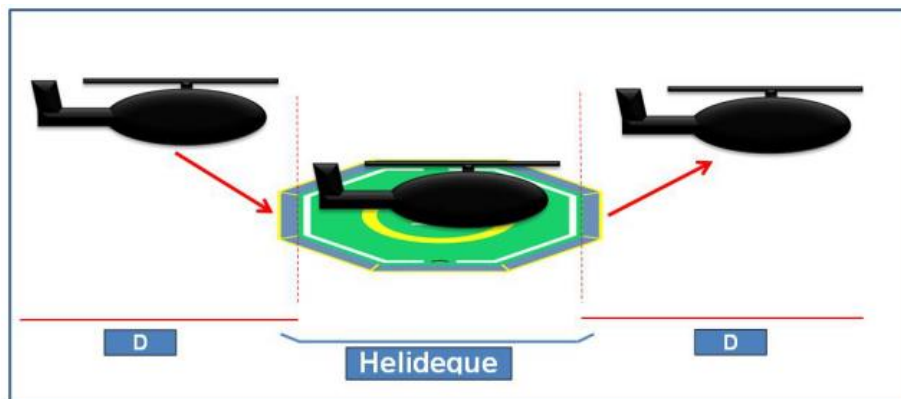

6.3.2.2 It shall be installed a dedicated display monitor in the Radio Room in place where the radio operator can see during the helicopter operation.

6.3.2.3 It shall be provided and installed a video recorder system, integrated with audio system, to record and store synchronized with audio all images relative to helideck operations, including approach, landing and take off of helicopters.

6.3.2.4 This video recorder shall have capacity to store the record registers for 90(ninety) days at least. All video recording shall be available to be retrieved any time when requested.

6.3.2.5 System shall have redundancy of hard disks to store files.

6.3.3 Audio and Video Recording Recovery Software

- 6.3.3.1 The recovery software shall have its access protected by login and password, with different level access for each user.
- 6.3.3.2 It shall be able to manually select audio and video passages so that they can be kept stored up to be manually removed.
- 6.3.3.3 Video and voice data shall be stored independently, but the software shall permit simultaneous playback on the same time base.

6.3.4 Closed rack for Audio and Video Recorder

- 6.3.4.1 It shall be provided an exclusive closed rack, locked by key, in order to housing all the audio e video recorders equipment.

7. UHF ACTIVE REPEATER SYSTEM

- 7.1. The UHF network for internal communication shall have a minimum of 05 (five) channels. The system shall be composed by an active repeater and antennas network, including leaky cables to guarantee communication between all portable radios without any shadow area anywhere in the unit. All these UHF antennas shall be connected to the Active Repeater cabinet coupler. The following drawing exemplifies the Active Repeater System arrangement.

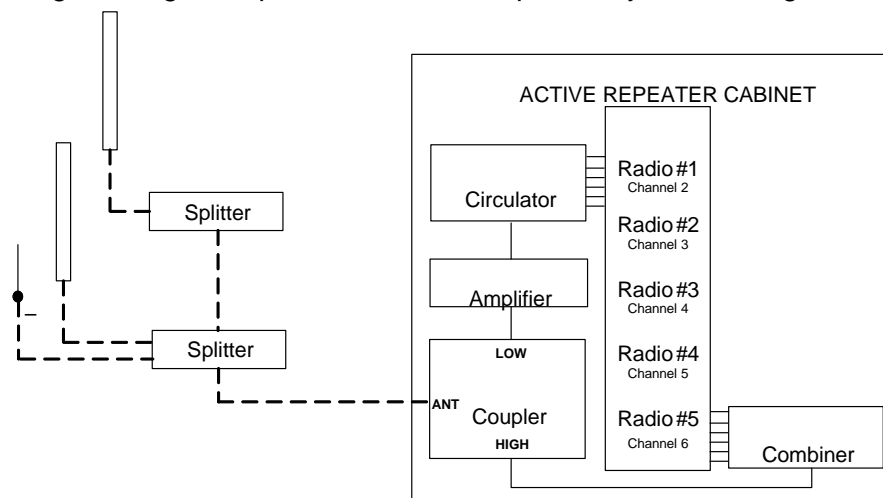

- 7.2. The active repeater shall enable 05 (five) simultaneous channels.
- 7.3. The active repeater equipment shall be housed in a 19 inches closed rack. The cable network shall be connected to the rack through combiners and circulators.
- 7.4. The Active Repeaters shall be powered by the AC essential bus bar. Under a failure condition of the main AC power supply, the system shall be kept working through a dedicated 12/24VDC power system with 30 (thirty) minutes minimum autonomy.
- 7.5. Calculation report covering all indoor and outdoor areas shall be developed and sent for BUYER approval.
 - 7.5.1. It shall be guaranteed the power level -75 dBm (or better) anywhere in the unit.
- 7.6. The equipment shall be homologated by ANATEL.
- 7.7. SELLER shall issue all documents to legalize the system according to Brazilian legislation.



- 7.8. All UHF repeaters shall use the digital modulation technology in order to comply with ANATEL Resolution 558/2010.
- 7.9. The UHF frequency plan, group ID and color code will be informed by BUYER during the detailed design to be configured.
- 7.10. The High frequencies (469,xxx MHz) shall be configured in the (TX) of active repeaters.
- 7.11. The Low frequencies (459,xxx MHz) shall be configured in the (TX) of portable radios.
- 7.12. The active repeater system shall enable simultaneous communications and shall use coaxial and leaked cables network.
- 7.13. It shall be supplied a Programming Kit, compound by software and cables to be used in maintenance and also to program the Active Repeater Radios during the unit operation.

7.14. UHF AUDIO RECORDING SYSTEM

- 7.15. It shall be provided an UHF audio recording system capable of recording all UHF communications on all channels simultaneously and maintaining storage for at least 30 days.
- 7.16. This system shall be powered by 220VAC UPS or by 24VDC from UHF active repeater system.

7.17. UHF SYSTEM - REMOTE ACCESS

- 7.17.1. The active repeater system shall have a remote access facility based on MOTOROLA SmartPPT solution for dispatch from BUYER onshore Remote Control Room;
- 7.17.2. The MOTOROLA SmartPPT solution shall be able to connect and access the five repeaters using the IP network.
- 7.17.3. It shall be provided one dedicated server to be installed at the FPSO to run the MOTOROLA SmartPPT software package.
- 7.17.4. It shall be provided and installed all licenses, for the Brazilian region, for perform the connection with existing BUYER SmartPPT system, to stablish an UHF radio communication from Remote Control Room located in BUYER onshore base station.
- 7.17.4.1. Including the Audio Reception Level License for the portable radios.
- 7.17.4.2. Including the onshore server license (to be informed by BUYER during the detailed design)
- 7.17.5. The licenses necessities for the Remote Control Room shall also be provided together with the UHF system.

8. PUBLIC ADDRESS AND GENERAL ALARM SYSTEM

- 8.1. The Public Address and General Alarm System (PAGA System) shall enable voice communication, operational announcements, priority announcements and safety warnings.
- 8.2. This system shall be dimensioned to broadcast sound signals in the whole Unit with a call line, alarm line and priority messages. In areas where the environment noise exceeds 90 dBA (according with NR-37), signaling lamps shall also be provided in addition to the alarm line.
- 8.3. The unit shall have a fully duplicated PAGA system, consisting of 02 (two) identical systems designated 'A' and 'B', which shall operate as independent units, such that failure of one system does not affect the operation of the other.



- 8.4. The acoustic coverage from the two systems shall be designed to be overlapping and reinforcing.
- 8.5. The "A" and "B" systems shall be installed in separate locations. The cable runs associated with each system ('A' and 'B') shall be physically separated. The PAGA ('A') system shall be installed in the Telecommunication Room and the system ('B') in another room as far as possible from the System A.
- 8.6. The PAGA system shall accept patch calls made through the PABX analog trunk (E&M).
- 8.7. The PAGA's power system shall be redundant, 220AC from essential electrical panel and 48 VDC from a dedicated DC power system comply with SOLAS/MODU/Classification Society rules.
- 8.8. CONTRACTOR shall submit to BUYER the approval document issued by Classification Society for the PAGA System.
- 8.9. The emergency alarm shall be operated in two ways: manually through access panels or through the Fire and Gas Detection system and only can be canceled manually.
- 8.10. Emergency announcements shall only be made through the access panels, while the operational announcements may also be made by remote access panels stations and by the telephone system.
- 8.11. The PAGA system (A and B) shall be able for remote management using the TCP / IP network interface.
- 8.12. Loudspeakers, visual alarms and all PAGA devices installed in all external areas shall be Zone 1 certified to enable the PA/GA system to continue operation in emergency level ESD-3.
- 8.13. The ICSS shall have a direct interface to the General Alarm (GA) system to allow the initiation of audible alarms.
- 8.14. The system shall be capable to mute the entertainment system during the alarms and priority announcements.
- 8.15. Alarms shall be muted during emergency announcements to ensure that instructions are intelligible.
- 8.16. The system shall be zoned in 02 (two) zones, as follow:
- Cabins in accommodation area,
 - Offices, workshops, entertainment rooms and common areas in accommodation module, topsides and engine room.
- 8.16.1. General announcements shall excluded Cabins in accommodation area,
- 8.16.2. Emergency announcements and alarms shall be automatic in all areas.
- 8.17. Following the typical design for PAGA System:

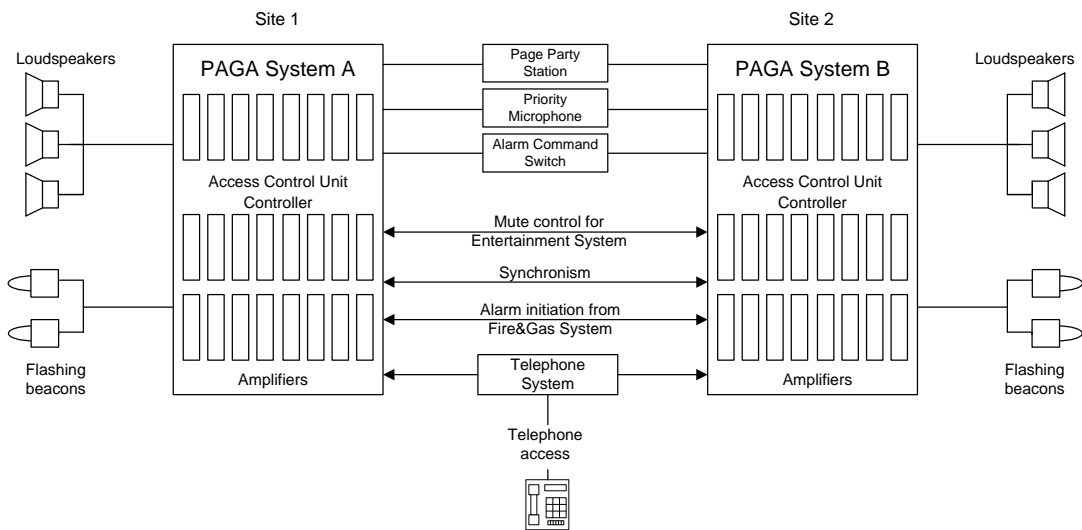

8.18. Emergency Signaling Lamp

- 8.18.1. Lamps shall be used together with the sound transducers in areas where the surrounding noise level exceeds 95 dBA. Lamps which indicate "Emergency" or "Prepare to Abandon" warnings will be white color and rotating or strobe type.
- 8.18.2. It shall be powered by UPS unit.

8.19. Alarms Tones Generator

It shall have at least one alarm tone generator in each PAGA system and it shall be able to be configured with the IMO - CODE ON ALERTS AND INDICATORS Resolution A.1021(26).

- **Emergency:** regular **1,000 Hz square wave** lasting approximately **1 second**, transmitted at equal intervals of approximately 1 second.
- **Prepare to Abandon:** Regular **1000 Hz square wave** of continuous duration.

8.20. Priority Microphone

8.21. It is a "push to talk" (PTT) type device, used for priority announcements. SELLER shall supply at least 03 priority Microphones installed in radio room, CCR and BUYER manager office.

Alarm Command Switch

- 8.21.1. It is a device that has 3 (three) electrical push-buttons ("Emergency", "Prepare to Abandon" and "Reset"), protected to prevent accidental operation, to activate the acoustic alarm signals or cancel them, and shall be strategically located on the FPSO.
- 8.21.2. It shall be installed at least 03 alarm command switches installed in radio room, CCR and BUYER manager office.

8.22. CALL UNITS (ACCESS PANELS)

- 8.22.1. It is a device located in strategic locations to make public announcements. It shall be installed at least in the following locations:



- 8.22.2. Central Control Room, Radio Room, near by the Lifeboats, helideck access, engine room, and Electric and Automation Room

8.23. PAGA - Remote Access

- 8.23.1. It shall be provided a Remote Access Panel to be installed onshore at BUYER Remote Control Room to allow PAGA remote access for operational announcements, emergency announcements and sound alarms.
- 8.23.2. The Remote Access Panel shall use the TCP/IP protocol to this connection.
- 8.23.3. SELLER shall consider for this solution provide a small PAGA cabinet, to be installed inside the onshore BUYER remote control room to provide these facilities (operational announcements, emergency announcements, alarm buttons and loudspeakers for sound alarms).

8.24. Sound Calculation definitions.

The sound pressure levels shall be enough for alarms and announcements to be intelligible throughout the unit. The sound pressure level and signal to noise ratio shall comply with at least the IMO / LSA code, as follows:

8.24.1. Emergency alarms

- a. The minimum sound pressure level in indoor environments, such as corridors, offices and entertainment rooms and outdoor environments shall be 80 dBA, with a minimum noise ratio of 10 dB.
- b. In cabins and cabin bathrooms, the minimum sound pressure level shall be 75 dBA, with a signal-to-noise ratio of 10 dBA.

8.24.2. Voice announcements

- a. The minimum indoor sound pressure level shall be 75 dBA, with a margin of at least 20 dB above the level of speech interference.
- b. For external environments, the minimum sound pressure level shall be 80 dBA, with a margin of at least 15 dB above the level of speech interference.

8.25. Amplifiers

- 8.25.1. All amplifiers shall be design for maximum of 80% of its nominal power
- 8.25.2. The system shall have 01 (one) spare amplifier in hot standby mode for each group of 05 amplifiers.

9. IPTV SYSTEM

- 9.1. The TV distribution system shall use IPTV technology and enable simultaneous reception and distribution of the number of channels required in this specification.
- 9.2. It shall provide dedicated LAN cables for the IPTV system. All switches for the distribution of the IPTV signal shall be independent of the corporate network and be interconnected to the management network of the BUYER corporate network.

- 9.3. IPTV system shall have a proper system for receiving satellite signals based on stabilized (auto-tracking) Ku Band antenna (1.2m diameter) to compensate all movements of the Unit and guarantee the signal level performance without variations.
- 9.4. The system shall be able to broadcast 48 (forty-eight) simultaneous pay TV channels, using a Brazilian PAYTV operator.
- 9.5. 01 (one) DVD player shall be provided as part of the TVRO system, installed inside the radio room. The DVD signals shall be distributed as an additional channel.
- 9.6. This system shall be installed in a closed rack with 19 inches for housing the IPTV equipment.
- 9.7. The IPTV signal shall be distributed to all cabins, briefing room, gym, recreation rooms, TV rooms, messroom, meeting rooms, cinema, TV room, game rooms, coordinators offices, central control room and radio room.
- 9.8. The SELLER shall provide a set-top box for each TV able to convert IP to HDMI, and also to distributing Wi-Fi IPTV inside each cabin.
- 9.9. It shall be supplied and installed OLED-TVs minimum with 32" (in accordance with NR-37) in all cabins, minimum with 65" recreation rooms, TV rooms, gym, and briefing room;
- 9.10. The system shall allow distribution of VOD - Video on Demand content.

10. UHF TV SYSTEM

- 10.1. A specific TV system shall be designed to tune in UHF TV signals generated by special service vessels (like PSV, DSV, AHTS), during their operation with the Unit. Only 01 (one) display in the CCR shall receive this signal. The receiver shall tune the whole UHF frequency band, as shown below.

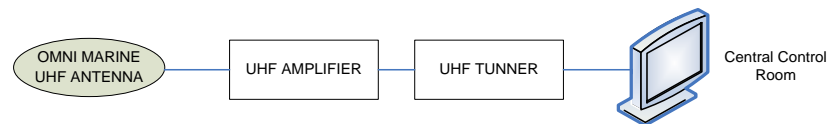

11. TELEPHONE SYSTEM

- 11.1. The description below aims to establish the requirements for FPSO TELEPHONE SYSTEM in the process areas, accommodation areas, offices, warehouses, workshops and machinery spaces.
- 11.2. For this system, it shall be supplied, installed and configured 01(one) Hybrid-PABX (IP and TDM) from UNIFY manufacturer, OpenScape 4000 V10 (or last version when commissioning) model or superior, with Brazilian version software.
- 11.3. This PABX shall be equipped to allow the following features:
 - a. 100 (a hundred) IP extension lines, with all licenses required;
 - b. 100 (a hundred) analog extension lines, with all licenses required;
 - c. 02 E1 trunk cards, with all licenses required;
 - d. 01 analog trunk (E&M);
 - e. 02 IP SIP trunk cards, with all licenses required;
 - f. SIP protocol licenses;
 - g. IP remote management interface for SNMP purposes;



- h. Redundant power supply;
- i. Interface with PAGA system

11.4. Additionally, it shall supply the following items:

- a. 150 (a hundred fifty) IP telephones SIP version, for the indoor areas, including licenses.

| | | |
|------------------|---------------------|-----|
| L30250-F600-C293 | OpenScape CP200 SIP | 100 |
| L30250-F600-C281 | OpenScape CP700 SIP | 50 |

- b. Patch panels and cables organizers.
- c. 400 (four hundred) patch cords.

11.5. PABX shall be powered by (-48 VDC, with Diod Drop Unit) power system.

11.6. PABX shall be housed in 19 inches rack.

11.7. PABX shall be connect to onshore base system by SIP protocol.

11.8. The Unit shall provide telephone booths with extension lines destined to private calls through the Brazilian public network, for use of the personnel onboard, in number according with Regulatory Standard of the Ministry of Labor NR-37. Each one of these telephones shall be placed in a closed cabinet providing full privacy.

12. INDUSTRIAL TELEPHONE SYSTEM

12.1. Telephones installed in outdoor areas shall be Zone 1 certified to enable the Telephony system to continue operation in emergency level ESD-3.

12.2. Industrial telephones shall be housed in booths with a level of protection suitable for the respective environmental conditions.

12.3. In areas with surrounding noise levels higher than 80 decibels, telephones shall be installed in acoustic booths according to the requirements below:

12.3.1. Acoustic booths located in areas with surrounding noise levels from 80 to 95 decibels must have an acoustic attenuation equal or higher than 20 decibels;

12.3.2. Acoustic booths located in areas with surrounding noise levels higher than 95 decibels must have an acoustic attenuation equal or higher than 35 decibels.

12.4. Telephones housed in acoustic booths must have "signal buzzers" and "signaling lamps" to perform the "ring sound" function, due the high noise area. These buzzers and lamps should be fed from the "UPS" or "battery system" to assure its operation at all times.

12.5. It shall be installed an industrial telephone in the following locations, minimum:

- a. 01 (one) in each Diving area
- b. 01 (one) near the helideck
- c. 01 (one) near each lifeboats
- d. 01 (one) near the offloading area
- e. 01 (one) in each workshop
- f. 01 (one) in each electrical panels room

- g. 01 (one) at the first floor of electrical and automation room
- h. 01 (one) in the temporary refuge
- i. At least 02 (two) in engine room
- j. At least 05 (five) telephones distributed in topside modules
- k. Offloading AFT
- l. Offloading FWD
- m. Boatswains store

12.6. Industrial telephone type shall be in accordance with the space requirements.

13. STRUCTURED VOICE AND DATA NETWORKS

13.1. The description below aims to establish the requirements of Local Area Network (LAN) in accordance with the requirements of ANSI/EIA/TIA 568-B2-1 and ISO 11801 for CAT 6 multimedia (voice and data) communications for BUYER exclusive use.

13.2. The network shall be designed in a star topology.

13.3. All LAN outlets and cables shall be properly labeled.

13.4. The Structured Cabling Network shall cover the following areas:

- a. 03 points in each workstation;
- b. 01 point in each office for printer;
- c. 12 points in the Central Control Room;
- d. 06 points in the Radio Room
- e. 03 points in Telecommunications Room
- f. 03 points in the Hospital
- g. 03 points in treatment room
- h. 03 points in the storekeeper's office
- i. 01 point in each telephone booth
- j. 04 points in each meeting room
- k. 04 points in Videoconference Room
- l. 04 points in the videoconference table
- m. 04 points in Heli waiting room
- n. 02 points in each cabin
- o. 02 points in each recreation area
- p. 06 points in messroom
- q. 02 points in galley
- r. 02 points in gym
- s. 02 points in laundry



- t. 03 points in each workstation of laboratory
 - u. 03 points in each dive area
 - v. 06 points in EAR – Electric and Automation Room
 - w. 02 points in each workshop additionally of the workstation
 - x. 06 points to automation rack in LIR (Local instrument room)
 - y. 10 points in internet café room
 - z. 03 points to the AIS Transponder
 - aa. 06 points inside the Metocean Data Acquisition System (ENV) system rack
 - bb. 12 points interconnecting all telecoms racks in telecom room
 - cc. 03 points inside the POS system rack
 - dd. 05 points inside the RRMS system rack
 - ee. 05 points inside the MODA system rack
 - ff. 01 point for each BUYER access point
 - gg. 06 points inside the CCTV system rack
 - hh. 06 points inside the UHF remote access system
 - ii. 03 points inside the VHF remote access system
 - jj. 03 points inside each PAGA cabinet
 - kk. 02 points inside each electrical panel (UPS panel, Essential panel and DC panels)
- 13.5. Areas outside the accommodation, in the industrial area or areas where cable lengths exceed 100 meters shall be cabled with optical fiber according to ANSI/EIA/TIA 568-B3, as described below.
- a. Optical fiber cable OM4 type with 6 fibers 50 x 125um with SC optic termination.
 - b. Fiber Optic shall be terminated in proper optical patch panel with SC termination and media converter (GigaEthernet RJ-45 electrical to SC optical termination) 19" rack standard inside BUYER Rack.
 - c. It shall be installed a media converter (GigaEthernet RJ-45 electrical to optical SC termination) at the end of the fiber cable to allow the connection with a workstation or telephone through FTP patch cord. The optic converters shall be housed in appropriated box.
 - d. Enough SC to SC optical cords shall be provided for both ends of such points.
- 13.6. All individual LAN cables from RJ 45 outlets shall be wired to the patch panels installed in LAN rack.
- 13.7. Structured Cabling Network shall be certified and an evidential report shall be submitted to BUYER.
- 13.8. Optic Cabling Network shall be certified and an evidential report shall be submitted to BUYER.

**13.9. FTP Category 6 Cabling**

- 13.9.1. Twisted pair cable (FTP) shall comply with the requirements of ANSI/EIA/TIA 568-B2-1 and ISO 11801 for Category 6 (CAT6).
- 13.9.2. The LAN cabling system shall use LSZH (Low Smoke Zero Halogen) FTP CAT 6 cable or other submitted for BUYER approval.
- 13.9.3. All FTP CAT 6 horizontal cabling shall be connected to the CAT 6 Patch Panels with 24 positions (1U high) in the rack in the Telecommunications Room.
- 13.9.4. All the FTP cables shall have both ends identified. All the other components of the network shall be identified in the same way: patch panel, fiber optic cables, patch cords and sockets.
- 13.9.5. All connections shall be according to EIA/T568-A standard.

13.10. CAT 6 RJ 45 Female Connectors

The RJ 45 female connectors shall comply with the requirements of Standard ANSI/EIA/TIA 568-B2 Category 6 and shall be used as access points in the work areas (outlets).

13.11. CAT 6 Patch Panel

The Patch Panel shall be metallic with 19 inches width, according to ANSI/TIA/EIA-310D, with 24 RJ-45 female ports and 1U of height. It shall be placed in the LAN racks in Telecommunication Room.

14. DATA EQUIPMENT**14.1. Core Switch**

- 14.1.1. It shall be supplied 02 (two) Core Switch with the minimum specs below:

| Product | Description | Quantity |
|-------------------|---|----------|
| WS-C3750X-24S-S | Catalyst 3750X 24 Port GE SFP IP Base | 1 |
| PWR-CAB-AC-BRA= | AC Power Cord (Brazilian), 1,5m | 2 |
| S375XVK9T-15002SE | CAT 3750X IOS UNIVERSAL WITH WEB BASE DEV MGR | 1 |
| CAB-STACK-50CM | Cisco StackWise 50CM Stacking Cable | 1 |
| CAB-SPWR-30CM | Catalyst 3750X Stack Power Cable 30 CM | 1 |
| GLC-SX-MMD | 1000BASE-SX SFP transceiver module, MMF, 850nm, DOM | 24 |
| GLC-T | 1000BASE-T SFP | 2 |

- 14.1.2. All switches shall have one DC power supply and one AC power supply.
- 14.1.3. All switches shall be powered by telecom DC power supply and essential AC.
- 14.1.4. It shall be supplied all optic cords to interconnect the equipment.

14.2. Electrical Access Switches

14.2.1. Each Electrical Access Switch shall be a CISCO Model WS-C3650-48PS-S or higher with the minimum specs below:

| Product | Description | Quantity |
|-----------------|--|----------|
| WS-C3650-48PS-S | Cisco Catalyst 3650 48 Port PoE 4x1G Uplink IP Base | 1 |
| PWR-C2-640WAC/2 | 640W AC Config 2 Secondary Power Supply | 1 |
| CAB-ACBZ-12A | AC Power Cord (Brazil) 12A/125V BR-3-20 plug up to 12A | 1 |
| PWR-C2-640WDC | 640W DC Config 2 Power Supply | 1 |
| GLC-SX-MMD | 1000BASE-SX SFP transceiver module | 2 |

14.2.2. Electrical Access Switches shall be dimensioned to connect all ethernet cables and also to have a margin of 25% spare ports for future expansions.

14.2.3. It shall be provided 04 (four) SFP GLC-SX-MM for each switch.

14.2.4. It shall be provided 06 (six) Fiber optic pig tail LC/PC with 5 meters.

14.2.5. It shall be provided 01 (one) stackable cable for each electrical switch.

14.2.6. All switches shall have one DC power supply and one AC power supply.

14.2.7. All switches shall be powered by telecom DC power supply and essential AC.

14.2.8. It shall be provided 400 (four hundred) CAT6 patch cords of 02 (two) meters each (blue color).

14.2.9. SELLER will be responsible for equipment basic configuration with all parameters provided by BUYER during the project detailed.

14.2.10. The firmware version required for this equipment to be connected in the BUYER NETWORK will be informed by BUYER during the project detailed.

14.3. Optical Access Switch

14.3.1. Each Optical Access Switch shall be a CISCO Model WS-C3850-24S-S or higher with the minimum specs below:

| Product | Description | Quantity |
|-----------------|--|----------|
| WS-C3850-24S-S | Cisco Catalyst 3850 24 Port GE SFP IP Base | 1 |
| PWR-C1-440WDC | 440W DC Config 1 Power Supply | 1 |
| PWR-C1-715WAC/2 | 715W AC Config 1 Secondary Power Supply | 1 |
| C3850-NM-4-1G | Cisco Catalyst 3850 4 x 1GE Network Module | 1 |
| CAB-TA-NA | North America AC Type A Power Cable | 1 |
| GLC-FE-100FX48 | 48 units of GLC-FE-100FX | 1 |
| GLC-SX-MMD | 1000BASE-SX SFP transceiver module | 2 |

14.3.2. Optical Access Switches shall be dimensioned to connect all demands including a margin of 25% spare ports for future expansions.

14.3.3. All switches shall have one DC power supply and one AC power supply.



- 14.3.4. All switches shall be powered by telecom DC power supply and essential AC.
- 14.3.5. SELLER will be responsible for equipment basic configuration with all parameters provided by BUYER during the project detailed.
- 14.3.6. The firmware version required for this equipment to be connected in the BUYER NETWORK will be informed by BUYER during the project detailed.
- 14.4. Switch for special services**
- 14.4.1. SELLER shall provide and install 01 (one) switch CISCO Model C9300L-24T-4G-E or superior for BUYER exclusive use.
- 14.4.2. It will be used to concentrate special monitoring systems required by BUYER.
- 14.4.3. SELLER will be responsible for equipment basic configuration with all parameters provided by BUYER during the project detailed.
- 14.4.4. The firmware version required for data equipment shall be the latest version available by manufacturer during the commissioning phase.
- 14.4.5. The switch shall be powered by Unit's UPS.
- 14.5. Switch for third party**
- 14.5.1. SELLER shall provide and install 01 (one) switch CISCO Model C9300L-24T-4G-E or superior for BUYER exclusive use.
- 14.5.2. It will be used to concentrate any third party system required by BUYER.
- 14.5.3. SELLER will be responsible for equipment basic configuration with all parameters provided by BUYER during the project detailed.
- 14.5.4. The firmware version required for data equipment shall be the latest version available by manufacturer during the commissioning phase.
- 14.5.5. The switch shall be powered by Unit's UPS.
- 14.6. 10G Switch for server cluster**
- 14.6.1. SELLER shall provide and install 04 (four) switches CISCO with 12 port UTP 10G for BUYER exclusive use.
- 14.6.2. It will be used to interconnect the corporative servers with corporative storage and to interconnect the DMZ servers with DMZ storage.
- 14.6.3. SELLER will be responsible for equipment basic configuration with all parameters provided by BUYER during the project detailed.
- 14.6.4. The firmware version required for data equipment shall be the latest version available by manufacturer during the commissioning phase.
- 14.6.5. Switches shall be powered by Unit's UPS.
- 14.7. WAN Router**
- 14.7.1. It shall be provided, installed and configured 02 (two) CISCO 4451 Integrated Services Router or higher with the minimum specs below:



| Product | Description | Quantity |
|------------------|---|----------|
| ISR4451-X-SEC/K9 | Cisco ISR 4451 Sec Bundle, w/SEC license | 1 |
| CON-SNT-ISX451-X | SNTC-8X5XNBD Cisco ISR 4451 Sec b | 1 |
| SL-44-IPB-K9 | IP Base License for Cisco ISR 4400 Series | 1 |
| GLC-SX-MMD | 1000BASE-SX SFP transceiver module, MMF, 850nm, DOM | 2 |
| PWR-4450-AC AC | Power Supply for Cisco ISR 4450 and ISR4350 | 1 |
| PWR-4450-DC/2 | DC Power Supply (Secondary PS) for Cisco ISR 4451 and 4351 | 1 |
| MEM-FLSH-8G | 8G eUSB Flash Memory for Cisco ISR 4430 | 1 |
| MEM-4400-DP-2G | 2G DRAM (1 DIMM) for Cisco ISR 4400 Data Plane | 1 |
| WAAS-RTU-2500 | WAAS and VWAAS Right to Use for 2500 connections | 1 |
| CON-ECMU-WS2500 | SWSS UPGRADES WAAS and VWAAS Right | 1 |
| PWR-COVER-4450 | Cover for empty 2nd Power Supply slot on Cisco ISR 4450 | 1 |
| POE-COVER-4450 | Cover for empty POE slot on Cisco ISR 4450 | 2 |
| ISRWAAS-RTU-2500 | ISRWAAS RTU for 2500 connections | 1 |
| SL-44-SEC-K9 | Security License for Cisco ISR 4400 Series | 1 |
| SL-44-APP-K9 | AppX License for Cisco ISR 4400 Series | 1 |
| MEM-44-4G 4G | DRAM (1 x 4G) for Cisco ISR 4400 | 1 |
| SM-S-BLANK | Removable faceplate for SM slot on Cisco 2900,3900,4400 ISR | 1 |
| SISR4400UK9-316S | Cisco ISR 4400 Series IOS XE Universal | 1 |
| SL-39-UC-K9 | Cisco Survivable Remote Site Telephony (SRST) License | 1 |
| SM-X-NIM-ADPTR | SM-X Adapter for one NIM module for Cisco 4000 Series ISR | 1 |
| NIM-4FXS | 4-Port Network Interface Module - FXS, FXS-E and DID | 1 |
| CAB-AC-BRA | Power Cord - Brazil, 10A,250V,2500mm, -40C to +85C | 1 |
| NAL-FOC-4451 | NAL Certification labels for ISR4451 | 1 |
| SL-44-UC-K9 | Unified Communication License for Cisco ISR 4400 Series | 1 |
| CAB-E1-RJ45BNC | E1 Cable RJ45 to Dual BNC (Unbalanced) | 2 |
| CAB-SS-V35MT | V.35 Cable, DTE Male to Smart Serial, 10 Feet | 2 |
| NIM-2CE1T1-PRI | 2 port Multiflex Trunk Voice/Channelized Data T1/E1 Module | 1 |
| NIM-2T | 2-Port Serial WAN Interface card | 1 |
| NIM-2GE-CU-SFP | 2-port GE WAN NIM, dual-mode RJ45 & SFP | 1 |
| PVDM4-64 | 64-channel DSP module | 1 |

14.7.2. SELLER will be responsible for equipment basic configuration with all parameters provided by BUYER during the project detailed.

14.7.3. The firmware version required for this equipment to be connected in the BUYER NETWORK will be informed by BUYER during the project detailed.

14.8. SD-WAN FIREWALL

14.8.1. SELLER shall provide, install and configure 02 (two) SD-WAN firewalls from Fortinet, model Fortigate 80F (FG-80F) or superior by the time of purchasing for BUYER exclusive use, according to the following specifications for each equipment.

14.8.2. The equipment shall be provided with the software licenses described below:

- a. Application Control



TITLE:

TELECOM MASTER SPECIFICATIONS FOR BOT UNITS

- b. IPS
- c. Anti-SPAM
- d. Webfiltering
- e. Advanced Malware Protection (AMP)
- f. Industrial Services
- g. SD-WAN Support
- h. Basic and advanced routing support, including OSPFv2, OSPFv3, MP-BGP

14.8.3. Interfaces:

- a. 2 (two) GE RJ45/SFP Shared Media Ports
- b. 2 (two) WAN GE RJ45 Port
- c. 6 (six) GE RJ45 Ports
- d. 2 (two) GE RJ45* FortiLink Port

14.8.4. Power:

- a. 12V DC, 3A with dual redundancy.
- b. All SDWAN firewalls power supplies shall be powered by the Unit's UPS.

14.8.5. Accessories:

- a. Rack mount tray

14.8.6. Installation requirements

- a. SELLER will be responsible for equipment basic configuration with all parameters provided by BUYER during the detailed design.
- b. The firmware version required for data equipment shall be the latest version available by manufacturer during the commissioning phase.
- c. SELLER shall provide 2 (two) GE SFP SX/LX Transceiver Module for connection with Core Switch.

14.8.7. Return Merchandise Authorization (RMA)

- a. SELLER shall provide RMA and Technical Support for all equipment licenses for 5 years or along contract duration.
- b. Service Level Agreement (SLA) shall be 8x5xNBD (next business day)

14.9. TYPICAL WAN TOPOLOGY

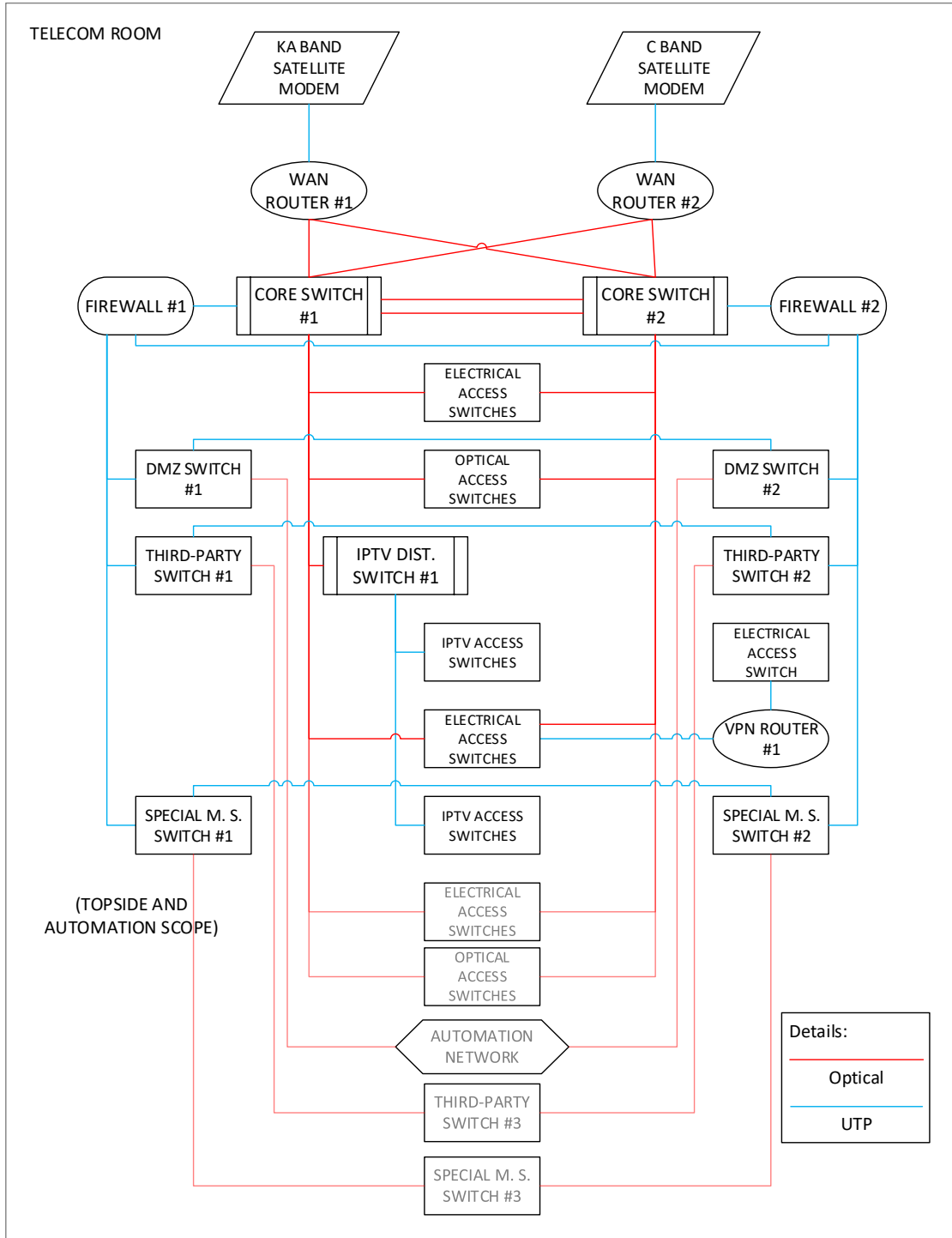



15. BUYER SERVERS

15.1. CORPORATIVE SERVER

15.1.1. It shall provide and install 03 (three) corporate servers, for BUYER exclusive use, with the following specifications (for each server):

- a. 19" rack-mountable servers, with maximum height of 1U;
- b. 2x processors (16) sixteen-core from AMD EPYC, Intel Xeon Scalable or better ;
- c. 512 GB, installed – DDR4 UDIMM 2666 Mhz or better Expansible until 512 GB or better, all memories modules for 16 GB – DDR4, or better.
- d. 01 (one) or more SVGA output, with DB-15 connector.
- e. 04 (four) or more USB 2.0 inputs.
- f. 01 (one) SAS RAID Controller, capable of implementing RAID 0 and 1 independent.
- g. 02 (two) SAS Hard Disk Drives, Hot-Swap, 10k RPM, 600GB.
- h. 04 (four) SAS Hard Disk Drives, Hot-Swap, 10k RPM, 1.2TB.
- i. 04 (four) or more 1-Gb Ethernet network interfaces, auto-sense, with RJ-45 connector.
- j. 01 (one) general purpose RS-232 interface, with DB-9 connector.
- k. 02 (two) power supplies, hot-plug and redundant, AC input, 110-220V, 50-60Hz, at least 90% efficiency.
- l. 01 (one) optical drive, capable to read CD-ROM and DVD-ROM.
- m. Sliding rails and cable management arm.
- n. Ethernet/IP-based integrated graphical remote console.
- o. The servers must be certified by Microsoft (HCL), Red Hat and Vmware for the two latest major versions of the following products at delivery time:
 - ✓ Windows Server.
 - ✓ Red Hat Enterprise Linux.
 - ✓ Vmware ESXi "Compatible operating system" with the last three major of ESXi.
- p. The Operating System and licenses shall not be provided.
- q. To provide all the peripheral, hardware, software and licenses (including licenses for remote configuration and management – ILO/IDRAC) needed to install the servers.

15.2. CORPORATIVE BACK UP SERVER

15.2.1. It shall provide and install 01 (one) corporate back up server, for BUYER exclusive use, with the following specifications:

- a. Veritas Backup Appliance 5250 technical specifications: Veritas minimum 72TB hardware capacity - Fully Redundant
- b. System memory: 64 GB
- c. Usable MSDP and Advanced Disk storage capacity (TiB): RAID 5
- d. Internal Storage Backup Capability: Minimum 72TB hardware capacity
- e. Spare Drives: Support for global Hot Spare



- f. Network Interface: 04 x 10Gbase-T (with 1GbE autoranging);
02 x 1GbE RJ45 Console for remote control;
01x 10Gb optic port (to interconnect to DMZ switch between decks)
- g. Back-end Connectivity: 12 Gb SAS
- h. Storage networking Protocols: NDMP / NFS
- i. Dimensions: 19" rack-mountable servers, 2U maximum height
- j. Power supply: 02 (two) AC power supplies redundant, hot plug, 220V, 50 ~ 60Hz
- k. Accessories: Sliding rails and cable management arm (rear organizer arms)
- l. Required Licensed Features (for all storage area): Full Bundle include replication another Veritas Appliance
- m. Replication Target: Veritas Appliance
- n. Services: 5 Years Warranty 24x7; Advanced Deployment.

The subscription and support shall be associated with PETROBRAS account, after the commissioning of equipment.

15.3. CORPORATE STORAGE SERVER

15.3.1. It shall provide and install 01 (one) corporate storage servers, for BUYER exclusive use, with the following specifications (for each server):

| | |
|-------------------------------------|---|
| Central Processing Unit (CPU) | 2x processors (22) twenty-two-core, 2.1 GHz from AMD, Intel Xeon or better |
| Memory (Random Access Memory - RAM) | 512 GB, installed - DDR4 LRDIMM 2666 Mhz or better Expansible until 3.0 TB, all memories modules for 128 GB – LRDIMM - DDR4 |
| SAS RAID Controller | Array controller SAS 12 Gb, SATA 6 Gb, capable of implementing RAID 0, 1, 5, 10; 2 (two) SAS 2.5" Hard Disk Drives, Hot-Swap, 10k RPM, 600GB |
| Internal Storage Capability | Initial and installed capability 50 TB – Hard Disk Drives or better Full and useful capability 200 TB – Hard Disk Drives or better |
| Display Adapter | Integrated Graphics Controller – up to 1920 x 1200@60Hz (32 bpp) - 16MB Video Memory |
| Interfaces | 4x USB 3.0, 1x HDMI, 1x SVGA (DB-15 connector), 1x COM Port (RS-232 – DB-9) |
| Network Interface | 4x Ethernet (RJ-45), Gigabit Ethernet – 1000 Mbps, or 2x Ethernet (RJ-45), 10 Gigabit Ethernet – 10000 Mbps, or 2x Ethernet (RJ-45), 25 Gigabit Ethernet – 25000 Mbps, and Remote control interface (iLO Remote) and manufacture software license to complete management |



TITLE: TELECOM MASTER SPECIFICATIONS FOR BOT UNITS

| | |
|---|---|
| I/O Expansion Slot | Minimum of 2 (two) PCIe 3.0 or better available with x8 lanes or higher; |
| Dimensions | 19" rack-mountable servers, 2U maximum height |
| Power supply | 2 (two) AC power supplies redundant, hot-plug, 110 ~ 220V, 50 ~ 60Hz |
| Accessories | Sliding rails and cable management arm 1 (one) optical drive, capable to read CD-ROM and DVD-ROM |
| Industry Standard Compliance | ACPI 6.1 Compliant PCIe 3.0 Compliant WOL Support Microsoft® Logo certifications PXE Support VGA/Display Port USB 3.0 Compliant (internal) USB 2.0 Compliant (external ports via SUV) Energy Star SMBIOS 3.1 UEFI 2.6 Redfish API IPMI 2.0 |
| Operating Systems and Virtualization Software Support | Windows Server 2012 R2 (Most Recent Version) Windows Server 2016 (Most Recent Version) VMware ESXi 6.0 U3 VMware ESXi 6.5 and U1 upon release CentOS Red Hat Enterprise Linux (RHEL) 6.9 and 7.3 SUSE Linux Enterprise Server (SLES) 11 SP4 and 12 SP2 Canonical Ubuntu ClearOS |
| Standard Features | Secure Digital 2.0 Advanced Encryption Standard (AES) Triple Data Encryption Standard (3DES) SNMP v3 TLS 1.2 DMTF Systems Management Architecture for Server Hardware Command Line Protocol (SMASH CLP) Active Directory v1.0 ASHRAE A3/A4 |

15.4. DMZ SERVER

15.4.1. It shall provide and install 05 (five) DMZ servers, for BUYER exclusive use, with the following specifications (for each server):

- a. 19" rack-mountable servers, with maximum height of 1U;
- b. 2x processors (16) sixteen-core from AMD EPYC, Intel Xeon Scalable or better ;
- c. 512 GB, installed – DDR4 UDIMM 2666 Mhz or better Expansible until 512 GB or better, all memories modules for 16 GB – DDR4, or better.
- d. 01 (one) or more SVGA output, with DB-15 connector.



- e. 04 (four) or more USB 2.0 inputs.
- f. 01 (one) SAS RAID Controller, capable of implementing RAID 0 and 1 independent.
- g. 02 (two) SAS Hard Disk Drives, Hot-Swap, 10k RPM, 600GB.
- h. 04 (four) SAS Hard Disk Drives, Hot-Swap, 10k RPM, 1.2TB.
- i. 04 (four) or more 1-Gb Ethernet network interfaces, auto-sense, with RJ-45 connector.
- j. 01 (one) general purpose RS-232 interface, with DB-9 connector.
- k. 02 (two) power supplies, hot-plug and redundant, AC input, 110-220V, 50-60Hz, at least 90% efficiency.
- l. 01 (one) optical drive, capable to read CD-ROM and DVD-ROM.
- m. Sliding rails and cable management arm.
- n. Ethernet/IP-based integrated graphical remote console.
- o. The servers must be certified by Microsoft (HCL), Red Hat and Vmware for the two latest major versions of the following products at delivery time:
 - ✓ Windows Server.
 - ✓ Red Hat Enterprise Linux.
 - ✓ Vmware ESXi "Compatible operating system" with the last three major of ESXi.
- p. The Operating System and licenses shall not be provided.
- q. To provide all the peripheral, hardware, software and licenses (including licenses for remote configuration and management – ILO/IDRAC) needed to install the servers.

15.5. DMZ Storage Server

15.5.1. It shall provide and install 01 (one) DMZ storage servers, for BUYER exclusive use, with the following specifications (for each server):

| | |
|-------------------------------------|---|
| Central Processing Unit (CPU) | 2x processors (22) twenty-two-core, 2.1 GHz from AMD, Intel Xeon or better |
| Memory (Random Access Memory - RAM) | 512 GB, installed - DDR4 LRDIMM 2666 Mhz or better Expansible until 3.0 TB, all memories modules for 128 GB – LRDIMM - DDR4 |
| SAS RAID Controller | Array controller SAS 12 Gb, SATA 6 Gb, capable of implementing RAID 0, 1, 5, 10; 2 (two) SAS 2.5" Hard Disk Drives, Hot-Swap, 10k RPM, 600GB |
| Internal Storage Capability | Initial and installed capability 50 TB – Hard Disk Drives or better Full and useful capability 200 TB – Hard Disk Drives or better |
| Display Adapter | Integrated Graphics Controller – up to 1920 x 1200@60Hz (32 bpp) - 16MB Video Memory |
| Interfaces | 4x USB 3.0, 1x HDMI, 1x SVGA (DB-15 connector), 1x COM Port (RS-232 – DB-9) |
| Network Interface | 4x Ethernet (RJ-45), Gigabit Ethernet – 1000 Mbps, or |



TITLE:

TELECOM MASTER SPECIFICATIONS FOR BOT UNITS

| | |
|---|---|
| | <p>2x Ethernet (RJ-45), 10 Gigabit Ethernet – 10000 Mbps, or 2x Ethernet (RJ-45), 25 Gigabit Ethernet – 25000 Mbps, and Remote control interface (iLO Remote) and manufacture software license to complete management</p> |
| I/O Expansion Slot | <p>Minimum of 2 (two) PCIe 3.0 or better available with x8 lanes or higher;</p> |
| Dimensions | <p>19" rack-mountable servers, 2U maximum height</p> |
| Power supply | <p>2 (two) AC power supplies redundant, hot-plug, 110 ~ 220V, 50 ~ 60Hz</p> |
| Accessories | <p>Sliding rails and cable management arm 1 (one) optical drive, capable to read CD-ROM and DVD-ROM</p> |
| Industry Standard Compliance | <p>ACPI 6.1 Compliant PCIe 3.0 Compliant WOL Support Microsoft® Logo certifications PXE Support VGA/Display Port USB 3.0 Compliant (internal) USB 2.0 Compliant (external ports via SUV) Energy Star SMBIOS 3.1 UEFI 2.6 Redfish API IPMI 2.0</p> |
| Operating Systems and Virtualization Software Support | <p>Windows Server 2012 R2 (Most Recent Version) Windows Server 2016 (Most Recent Version) VMware ESXi 6.0 U3 VMware ESXi 6.5 and U1 upon release CentOS Red Hat Enterprise Linux (RHEL) 6.9 and 7.3 SUSE Linux Enterprise Server (SLES) 11 SP4 and 12 SP2 Canonical Ubuntu ClearOS</p> |
| Standard Features | <p>Secure Digital 2.0 Advanced Encryption Standard (AES) Triple Data Encryption Standard (3DES) SNMP v3 TLS 1.2 DMTF Systems Management Architecture for Server Hardware Command Line Protocol (SMASH CLP) Active Directory v1.0 ASHRAE A3/A4</p> |

16. PI INTERCONNECTION**16.1. FIREWALL**

- 16.1.1. SELLER shall provide, install and configure 02 (two) SDWAN firewalls from Fortinet, model Fortigate 80F (FG-80F) or superior by the time of purchasing for BUYER exclusive use, according to the following specifications for each equipment.
- 16.1.2. The equipment shall be provided with the software licenses described below:
- a. Application Control
 - b. IPS
 - c. Anti-SPAM
 - d. Webfiltering
 - e. Advanced Malware Protection (AMP)
 - f. Industrial Services
 - g. SD-WAN Support
 - h. Basic and advanced routing support, including OSPFv2, OSPFv3, MP-BGP
- 16.1.3. Interfaces:
- a. 2 (two) GE RJ45/SFP Shared Media Ports
 - b. 2 (two) WAN GE RJ45 Port
 - c. 6 (six) GE RJ45 Ports
 - d. 2 (two) GE RJ45* FortiLink Port
- 16.1.4. Power:
- a. 12V DC, 3A with dual redundancy
 - b. All SDWAN firewalls power supplies shall be powered by the unit's UPS.
- 16.1.5. Accessories:
- a. Rack mount tray
- 16.1.6. Installation Requirements
- a. SELLER will be responsible for equipment basic configuration with all parameters provided by BUYER during the detailed design.
 - b. The firmware version required for data equipment shall be the latest version available by manufacturer during the commissioning phase.
 - c. SELLER shall provide 2 (two) GE SFP SX/LX Transceiver Module for connection with Core Switch.
- 16.1.7. Return Merchandise Authorization (RMA)
- a. SELLER shall provide RMA and Technical Support for all equipment licenses for 5 years or along contract duration.
 - b. Service Level Agreement (SLA) shall be 8x5xNBD (next business day).

16.2. DMZ SWITCH

- 16.2.1. SELLER shall provide and install 02 (two) switches CISCO Model C9300L-48T-4G-E or superior for BUYER exclusive use.
- 16.2.2. SELLER will be responsible for equipment basic configuration with all parameters provided by BUYER during the project detailed.
- 16.2.3. The firmware version required for data equipment shall be the latest version available by manufacturer during the commissioning phase.
- 16.2.4. DMZ switch shall be powered by Unit's UPS.

16.1. PI TOPOLOGY

Following below is the BUYER topology standardized for PI interconnection between BUYER offshore network and BUYER onshore network during the SELLER operation phase.

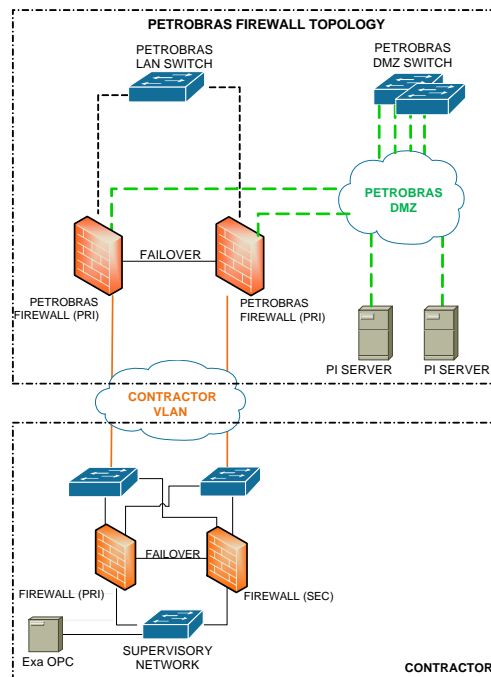

17. INMARSAT

- 17.1. It shall be supplied and installed a complete Inmarsat Fleet Broadband 250 for voice contingency communication service segregated of the main circuit.
- 17.2. One extension line shall be installed in the Radio Room and another one in the CCR
- 17.3. It is supposed to be used any time, if the main external VSAT system fails.
- 17.4. BUYER will be responsible for contract the service provider.

18. BUYER WIRELESS LAN – WLAN

18.1. It shall be provided, installed and configured a Wireless Local Area Network (WLAN), standard standard IEEE 802.11ax (WiFi 6), with coverage all areas inside the accommodation module, all outside areas, workshops, warehouse, main deck, machinery area and all topside modules without any shadow areas.

18.2. The WLAN shall be composed for the following equipment and comply with the following requirements:

18.2.1. APs (Access Points)

- a. The wireless equipment shall be compliance with Brazil Regulatory Domain.
- b. To comply with BUYER network requirements, the equipment shall be manufactured by CISCO.
- c. All equipment shall be homologated by ANATEL.
- d. Aps (Access Points) shall be Cisco Catalyst 9100 Access Points or superior with Cisco DNA Essentials with subscription term for 07 years.
- e. For zone 1 areas it shall be installed access point inside the Extronics / iWAP107 enclosure box.
- f. APs (Access Points) shall be connected to BUYER switches and powered by PoE (Power over Ethernet);
- g. APs (Access Points) installed more than 90m from the switch shall use fiber optic cables connected to optic/Ethernet converters and AC powered.
- h. The authentication of users and APs will be made by the controller in BUYER existing RADIUS server onshore.
- i. Coverage shall be dimensioned to enable data rates of 24 Mbps at minimum.
- j. A site survey report shall be issued by SELLER showing the required coverage.
- k. It shall consider the -67dBm as minimum level acceptable.
- l. SELLER will be responsible for equipment basic configuration with all parameters provided by BUYER during the project detail.
- m. Aps (Access Points) model shall be compatible with Cisco WLAN controller supplied via local registration (lightweight mode).

18.2.2. WLAN Controller

- a. WLAN Controller shall be C9800-L-C-K9 Series Wireless Controller with Cisco DNA Essentials for up to 250 Cisco access points, and 19" rack mounted kit.
- b. SELLER will be responsible for equipment basic configuration with all parameters provided by BUYER during the project detailed.
- c. The firmware version required for data equipment shall be the latest version available by manufacturer during the commissioning phase.

NOTE: SELLER shall ensure that the WLAN controller's IOS and access points are able to function smoothly by making it possible for the access points to register with the WLAN controller.

18.2.3. WLAN dimensioning criteria

- a. SELLER shall ensure WLAN signal covering all Accommodation Module and Hull Industrial Areas.
- b. The SELLER shall use a WLAN Site Survey software and accessories, if necessary, to create the Predictive Report.

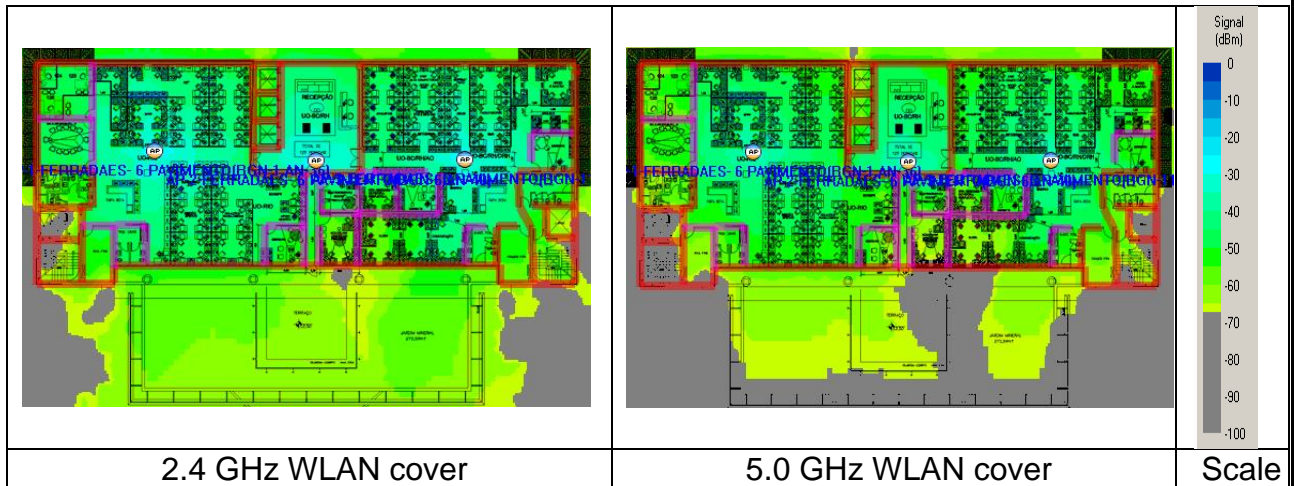

- c. SELLER shall consider the following WLAN detailed design requirements for 2.4 GHz and 5 GHz:

| | |
|--|------------|
| Minimum AP signal strength required | - 67 dBm |
| Minimum AP PHY Data Rate required - Uplink | 54,00 Mbps |
| Minimum AP PHY Data Rate required - Downlink | 54,00 Mbps |
| Signal Noise Ratio required | 25 dBm |
| Maximum Noise Level Desired | - 90 dBm |
| 40 MHz Channel Width | Allowed |
| 20 MHz Channel Width | Allowed |
| 80 MHz Channel Width | Allowed |
| 160 MHz Channel Width | Allowed |

19. BUYER TELECOMMUNICATION ROOM

- 19.1. It shall be provided an adequate room with redundant air-conditioned for installation of telecommunication equipment.
- 19.2. It shall be provided and installed cable trays in the Telecommunication Room for adequate equipment installation.
- 19.3. It shall be provided and installed 01 (one) 2/0 AWG bare copper cable in the Telecommunication Room for the electrical grounding of equipment.



19.4. In this room shall be installed all racks and electrical panels necessary for telecommunications systems.

19.5. It shall be provided and installed 01 (one) workstation, 01 (one) bookshelf for manuals and 03 (three) cabinets for tools and instruments.

20. TELECOMMUNICATIONS RACKS

20.1. All racks for the telecom systems shall follow the specification below:

- a. It shall be closed, 19 inches standard, 40U height, minimum depth of 1000 mm (internal dimensions) and 800 mm of useful width (internal dimensions).
- b. It shall have AC universal standard sockets 19 inches standard.
- c. Glazed door at the front.
- d. 04 (four) fans installed in the rear.
- e. 02 (two) vertical cable organizers.
- f. Internal light.

20.2. The following equipment shall be installed in LAN racks:

- a. Electrical and optical Access switches
- b. Patch panels
- c. Patch panel for racks interconnection
- d. 19" inches DC switchboard
- e. 19" inches AC switchboard
- f. ATS (Automatic Transfer Switch) when applicable.
- g. AC outlets.

20.3. The following equipment shall be installed in WAN rack:

- a. Core Switches
- b. 02 (two) routers
- c. 02 (two) SD WAN firewalls
- d. 19" inches DC switchboard
- e. 19" inches AC switchboard
- f. ATS (Automatic Transfer Switch) when applicable.
- g. Patch panel for racks interconnection
- h. AC outlets.

20.4. The following equipment shall be installed in VSAT rack:

- a. VSATs antenna controller
- b. VSAT modems

- c. LEO modem
- d. 19" inches DC switchboard
- e. 19" inches AC switchboard
- f. ATS (Automatic Transfer Switch) when applicable.
- g. Patch panel for racks interconnection
- h. AC outlets.

20.5. The following equipment shall be installed in SERVER rack:

- a. Corporate servers, back up server and Storage
- b. DMZ servers and Storage
- c. DMZ Switches
- d. 10G switches for Servers clusters
- e. 02 (two) DMZ firewalls
- f. 02 (two) DMZ Switches
- g. 19" inches DC switchboard
- h. 19" inches AC switchboard
- i. ATS (Automatic Transfer Switch) when applicable.
- j. Patch panel for racks interconnection
- k. AC outlets.

20.6. Additionally, it shall be provided a dedicated rack for IPTV, CCTV, 4G/LTE, POB, POS, PRS, ENV, PAGA, UHF Active repeater, VHF remote access and PABX system.

20.7. RACKS FOR FUTURE EQUIPMENTS

20.7.1. Additionally, it shall be installed 02 (two) extra racks with the specifications below:

20.7.2. It shall be closed, 19 inches standard, 40U height, minimum depth of 1000 mm (internal dimensions) and 800 mm of useful width (internal dimensions).

20.7.3. It shall have AC universal standard sockets 19 inches standard and fan;

20.7.4. The following equipment shall be installed in extra rack:

- a. 01 (one) optical amplifier (supplied by BUYER – Future installation)
- b. 01 (one) DWDM equipment (supplied by BUYER - Future installation)
- c. 01 (one) 19 inches DC switchboard
- d. 01 (one) 19 inches AC switchboard
- e. Optical patch panel for fiber optics from submarine optic cable
- f. Patch panel for racks interconnection
- g. AC outlets.



20.8. OPERATOR TELECOMM RACK

- 20.8.1. OPERATOR shall install one rack inside the BUYER telecom room in order to sheltering all its own equipment foreseen for its own telecom system.
- 20.8.2. This rack shall be installed beside the BUYER LAN RACK to enable sharing the LAN structured cabling.
- 20.8.3. It shall be closed, 19 inches standard, 40U height, minimum depth of 1000 mm (internal dimensions) and 800 mm of useful width (internal dimensions).
- 20.8.4. It shall have AC universal standard sockets 19 inches standard and fan;

21. VIDEOCONFERENCE SYSTEM

21.1. Videoconference Room

21.1.1. It shall provide a meeting room that will also be used as a videoconference room by BUYER. This room shall be in the same deck as the BUYER' Representative office and as close as possible to it.

21.1.2. The following requirements shall be considered:

- a. Meeting table: 04 (four) BUYER LAN sockets and 04 (four) 220 VAC power sockets shall be provided groomed in the middle of the table.
- b. 03 (three) 220 VAC power sockets shall be provided near the videoconference equipment and TVs;
- c. 02 (two) BUYER LAN socket shall be provided near the CODEC videoconference equipment.

21.2. BUYER Videoconference Equipment

21.2.1. SELLER shall supply and install the following equipment in the videoconference room, complying with BUYER' videoconference network:

- a. 01 (one) **YEALINK MVC860** Room Kit Solution for **MICROSOFT TEAMS ROOM** or a more recent model, with accessories and licenses in order to allow content sharing;
- b. The kit shall include:
 - I. 01 (one) mCore mini-PC (Windows IoT)
 - II. 01 (one) UVC86 camera with TV mount kit and wall mount kit
 - III. 01 (one) mTouch II touch panel (on the table), including content sharing cable (HDMI adapter)
 - IV. 01 (one) Yealink remote control
 - V. 01 (one) VCM34 microphone (on the table)
 - VI. 02 (two) mSpeaker II soundbars (below TVs)
 - VII. 01 (one) 4-port PoE (802.3af) switch – Yealink RCH40 or similar

- VIII. 01 (one) 5 meters USB 3.0 cable type A male to B male (camera x mCore)
- IX. 03 (three) 3 meters pre-made CAT5e cables
- X. 01 (one) UVC86 x switch
- XI. 02 (two) Soundbars x switch
- XII. 02 (two) 10m pre-made CAT5e cables
- XIII. 01 (one) mTouch x mCore
- XIV. 01 (one) VCM34 x switch
- XV. 02 (two) 3m HDMI 3.0 cable (TVs x mCore)

c. 02 (two) 65" OLED TVs wall mounted side by side with HDMI-IN interfaces.

21.2.2. BUYER will be responsible for this equipment configuration.

21.2.3. Following the videoconference room design proposal.



21.3. Hospital Videoconference Equipment

21.3.1. SELLER shall supply and install a videoconference system in the Hospital, as follow:

- a. 01 (one) YEALINK MVC-S40 Room Kit Solution for MICROSOFT TEAMS ROOM or a more recent model, with accessories and licenses in order to allow content sharing;
- b. The kit shall include:
 - I. mCore mini-PC (Windows IoT)
 - II. UVC S40 camera with TV mount kit
 - III. mTouch II touch panel, including content sharing cable (HDMI adapter) and wall mount (to be attached to the cart)
 - IV. 1x Yealink remote control
 - V. 1x 5m USB 3.0 cable type A male to B male (camera x mCore)
 - VI. 1x 5m pre-made CAT5e cable (mTouch x mCore)
 - VII. 1x 3m HDMI 3.0 cable (TV x mCore)

c. 01 Pedestal (CART) for 46" OLED TV and videoconference equipment installation;

d. Videoconference equipment shall be arranged in Hospital or Treatment Room, so that camera can focus on injured patient on stretcher and doctor.

21.3.2. BUYER will be responsible for this equipment configuration.

21.3.3. Following the typical videoconference pedestal:



21.4. Central Control Room Equipment

21.4.1. SELLER shall supply and install a videoconference system in the CCR, as follow:

a. 01 (one) YEALINK MVC-S40 Room Kit Solution for MICROSOFT TEAMS ROOM or a more recent model, with accessories and licenses in order to allow content sharing;

b. The kit shall include:

VIII. mCore mini-PC (Windows IoT)

IX. UVC S40 camera with TV mount kit

X. mTouch II touch panel, including content sharing cable (HDMI adapter) and wall mount (to be attached to the cart)

XI. 1x Yealink remote control

XII. 1x 5m USB 3.0 cable type A male to B male (camera x mCore)

XIII. 1x 5m pre-made CAT5e cable (mTouch x mCore)

XIV. 1x 3m HDMI 3.0 cable (TV x mCore)

c. 01 (one) 46" OLED TV

d. Videoconference equipment shall be arranged in CCR so that camera can focus the operator's desks.

21.4.2. BUYER will be responsible for this equipment configuration.

22. VSAT SYSTEM

22.1. It shall be provided, installed and commissioned, for BUYER exclusive use, two different and independents VSATs systems as described below:

22.1.1. **Ka-band system** - VSAT solution based on O3b mPower from SES technology or similar, with 03 (three) stabilized antennas (auto-tracking) with at least 2,2 meters diameter and all

of others parts of the system, like BUC, LNB and modem compatible and able to operate with minimum bandwidth of 25 + 25 Mbps.

22.1.2. Ku-band system with the specifications below:

| Equipment | Description | Quantity |
|-----------------|--|------------------|
| VSAT - BUC | Model - To be defined during de detailed design | 01 + 01 SPARE |
| VSAT - MODEM | Model - To be defined during de detailed design | 01 + 01 SPARE |
| Antenna | Stabilized 2,2m diameter (minimum) C/Ku dual-Band antenna, Homologated by ANATEL | 01 |
| Antenna (spare) | Antenna standard spare parts kit | 01 |
| LNB | LNB PLL Ku-Band | 01 + 01 SPARE |

22.2. BUYER will be responsible for contracting the satellite provider carrier (O3B and Ku-band) including all costs regarding to this service and the circuit from the satellite Provider HUB to BUYER base station.

22.3. Both circuits shall be connected to BUYER Router in the FPSO and SELLER will be responsible for installing the proper cable between the router and modems.

22.4. VSAT system shall be assembled, configured and tested by SELLER at shipyard.

22.5. The system shall be commissioned by Vendor representative technician in Brazil as soon as the FPSO arrives in Brazil.

22.6. SELLER shall send all the scheduled tests and set up parameters for BUYER evaluation, prior to the tests at shipyard.

22.7. SELLER shall inform BUYER at least 45 days before the tests and inspections in the shipyard.

22.8. The pedestal for VSAT antenna installation shall guarantee a safety access for the telecoms technician.

22.9. SELLER shall send all VSAT documents to BUYER, in order to BUYER legalize the systems at ANATEL.

23. VSAT SYSTEM FOR THE SELLER OPERATION PERIOD

23.1. SELLER shall install its own VSAT system totally independent of the VSAT BUYER solution, or SELLER can share the BUYER KU/C-Band solution. To do this, SELLER must contract an independent carrier for its use.

24. LEO (LOW EARTH ORBIT) SATELLITE

24.1. SELLER shall provide a broadband internet connection via an independent and exclusive (LEO) satellite system to serve BUYER, meeting the following technical specifications:

- a. SELLER shall install and configure 02 (two) kits consisting of 01 (one) antenna, 01 (one) modem-router and 01 (one) power supply each one of a (LEO) Low Earth Satellite system.
- b. All system components shall be powered by the Unit's UPS

- c. SELLER shall install the antenna in a place where there is no obstruction of its vertical field of vision according to technical information from provider for maritime installations where the unit will operate;
- d. SELLER shall provide all cables, adaptors and accessories necessary to provide the interconnections.
- e. Kit shall be connected to ethernet equipment using RJ-45 connector.
- f. BUYER will be responsible for the service contract.

25. DC POWER SYSTEM

25.1. It shall be provided a DC power supply (-) 48VDC/ 200A (positive grounded) with the following main electrical characteristics:

Rated input voltage = 220 VAC

Rated oFTP voltage = (-) 48 VDC

Floating voltage (oFTP) = -52.8 VDC

Recharge voltage (oFTP) = -57.6 VDC

Final discharge voltage (oFTP) = - 43.2 VDC

UDQ module

25.2. The system shall have 02 (two) batteries banks dimensioned to keep the system for 02 (two) hours at minimum.

25.3. The system shall have IP management interface

25.4. DC Switchboard

25.4.1. It shall be provided 01 (one) 19 inches rack mounted -48 VDC switchboard in each telecoms' Rack;

25.4.2. The switchboard shall be provided with 04 (four) 6 A circuit breakers and 04 (four) 10 A circuit breakers.

25.5. AC Switchboard

25.5.1. It shall be provided 01 (one) 19 inches rack mounted AC switchboard in each telecoms' rack.

25.5.2. The AC switchboards shall be fed by 220 VAC from UPS A and B (main and redundant) bus-bar.

25.5.3. Each AC switchboard shall be provided with 10 (ten) 10 A circuit-breakers.

25.5.4. All equipment installed in telecoms' Racks shall be fed by these switchboards.

25.5.5. Each rack shall have 02 (two) 19 inches outlets of at least 06 (six) sockets, installed at its rear.

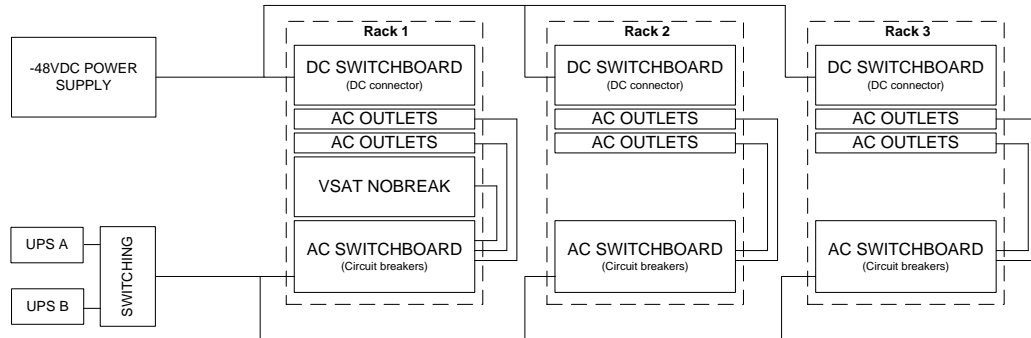
25.6. Proposed drawing for power system inside telecoms racks.

26. INFRASTRUCTURE FOR SUBMARINE FIBER OPTIC NETWORK

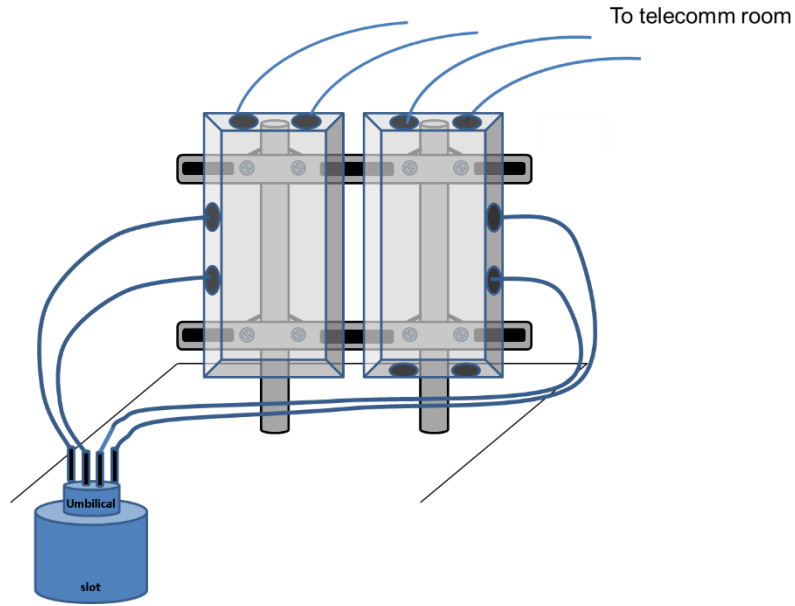
- 26.1. It shall be provided all proper infrastructure in order to connect the FPSO to the BUYER submarine fiber optic network.
- 26.2. The following items shall be provided and installed by SELLER:
- 26.2.1. One dedicated I tube for 01 (one) dedicated optic umbilical.
- 26.2.2. It shall be installed 02 (two) fiber optic cables from BUYER telecom room to riser Balcony area with the following specs:
- 12 (twelve) single mode fibers optics each one;
 - Cable insulation shall be Low Smoke Zero Halogen;
- 26.3. The fibers optics shall be according to ITU-T G series recommendations and the technical characteristics of recommendation G.652D.
- 26.4. On the 1550nm window, the fiber optic shall have the following characteristics:
- Attenuation less than or equal to 0.25 db/km
 - Dispersion less than or equal to 18.00 ps/nm.km
 - Dispersion Slope less than or equal to 0.088 ps/nm².km
 - PMD less than or equal to 0.20 ps/ $\sqrt{\text{km}}$
 - Effective area less than or equal to 76 μm^2
- 26.5. It shall be installed close to I-Tube destined to submarine optical cable pull-in, in riser balcony area, an Ex-d Junction box to protect the optic splices between optic submarine cable and topside optic cable;

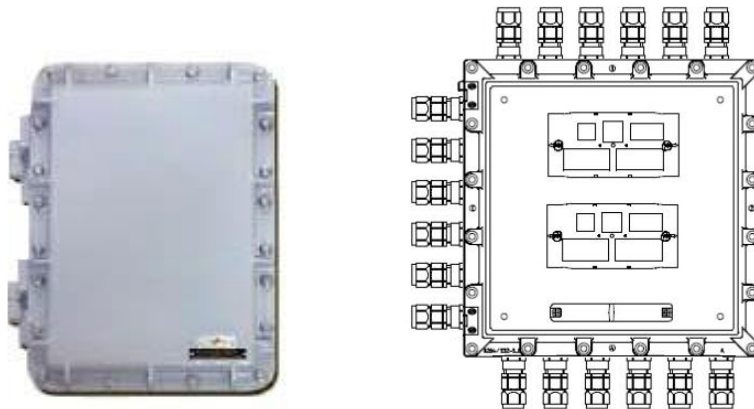

Typical arrangement



Ex-d Junction box



Splice cassette for securing single optical fiber splices Installed inside the Ex-d Junction box



- 26.6. The cable route from selected I-TUBE (destined to submarine optical cable pull-in) to Ex-d Junction box shall be at most 02 meters length.
- 26.7. All fiber optic cables, inside the BUYER Telecommunication Rack, shall be terminated in 01 (one) optical patch panel 19" inches with E2000/APC connectors.
- 26.8. The optical cables shall be installed in appropriated cable trays from riser balcony area to BUYER Telecommunication Room to ensure that no mechanical stresses occur and as well as no curve greater than specified by the manufacturer.

27. RADIO ROOM

- 27.1. It shall be provided an exclusive radio room for the radio communication system.
- 27.2. In the Radio Room, it shall be installed the GMDSS radio console, operational radio console, CCTV monitor, Meteorological and Positioning System displays (HMS System) monitor, computer, and others radio equipment.

28. COMPUTERS AND PRINTERS

- 28.1. It shall be provided computers and printers for BUYER exclusive uses.

28.2. Computers:

- 28.2.1. It shall be supplied 50 (fifty) computers with the minimum configuration below:

| | |
|-------------------------------------|--|
| Central Processing Unit (CPU) | Intel Core i9- 13900KS, released in the last 18 months or better latest generation (or equivalent) |
| Memory (Random Access Memory - RAM) | 16GB DDR4 or better |
| Display Adapter | Video card with 2GB GDDR5 graphics memory |
| Secondary Storage | 512 GB internal Solid State Drive (SSD) |
| Operational System | Microsoft Windows 11 professional x64 |
| Interfaces | Front: 2x USB 3.0, 1x Line in, 1x Head Phone (Line Out) Rear: 1x DC in, 2x USB 3.0, 1x HDMI |
| Network Interface | 1x Ethernet (RJ-45), Gigabit Ethernet – 10/100/1000 Mbps – DASH 1.1 supported |
| Dimensions | Cabinet: 200 x 200 x 50 mm or less |
| Accessories | Keyboard (ABNT2 standard) and Mouse – optic |
| Monitor | 24" LCD monitor |
| Power | AC – 100 ~ 240V / 50 ~ 60 Hz |

- 28.2.2. Accessories for each computer: webcam, mouse, keyboard, speakers

28.3. Printers

- 28.3.1. It is a device that consolidates the functionality of a printer, copier, scanner into one machine and with all following basic characteristics:
 - a. Documents printing;

- b. Documents copying;
- c. Documents digitalization;
- d. Copy Resolution 600 x 600 dpi
- e. Automatic two-sided printing (duplex);
- f. Automatic two-sided document feeder for scanning function;
- g. Collect and send multiple documents in a single file;
- h. Network interface (LAN): RJ-45, Ethernet standard, TCP/IP V4 compatible (IPv4);
- i. Support, at least, A3 and/or A4 size paper;

28.3.2. It shall be provided 10 (ten) printers with the configuration below:

- a. Small Multifunction Printer;
- b. Color Laserjet/LED Printing technology;
- c. Standard 500 sheets capacity, at least;
- d. Paper Feed size A4 (210 x 297 mm);

28.3.2.1. It shall be provided 10 kits of each color tonner compatible with the printer model provided.

28.3.3. It shall be provided 10 (ten) printers with the configuration below:

- a. Medium Multifunction Printer;
- b. Color Laserjet/LED Printing technology;
- c. Standard 500 sheets capacity, at least;
- d. Paper Feed size A4 (210 x 297 mm) and A3 (297 x 420 mm);

28.3.3.1. It shall be provided 10 kits of each color tonner compatible with the printer model provided.

29. INTERNET CAFE

29.1. It shall be provided and installed 02 (two) VPN router Cisco ISR4331 model or superior, for exclusive use on Internet Room, with the following specs below, or better:

| Code | Description | Qty |
|------------------|---|-----|
| ISR4331-X-SEC/K9 | Cisco ISR 4451 Sec Bundle, w/SEC license | 1 |
| HWIC-2FE | Two 10/100 routed port HWIC | 1 |
| CAB-C13-ACB | AC Power Cord (Brazil), C13, NBR 14136, 2.1M1 | 1 |

29.2. BUYER will be responsible for this equipment configuration.

29.3. It shall provide an internet café room equipped with individual computers, connected to the internet for private communication according to NR-37.



29.4. Computers for Internet cafe:

It shall be supplied 10 (ten) computers with the minimum configuration below:

- a. Processor (CPU): Intel Core i9- 13900KS, released in the last 18 months or better latest generation (or AMD PRO equivalent);
- b. Operating System: Microsoft Windows 11 professional x64;
- c. RAM memory: 16GB DDR4
- d. Storage: 512 GB internal Solid State Drive (SSD)
- e. Video card with 2GB GDDR5 graphics memory
- f. Monitor: 24" LCD monitor;
- g. I/O ports: 01 Audio in/out and Microphone Port; 01 HDMI; 04 USB; 01 Network Port
- h. Accessories for each computer: webcam, mouse, keyboard, speakers

30. CCTV SYSTEM

30.1. General requirements

- 30.1.1. A CCTV IP system shall be provided, installed and configured, including all equipment, software, licenses and accessories
- 30.1.2. CCTV system shall be designed to allow the operator to take on-distance decisions, or further allow the monitoring of hazardous places or a difficult access, thus avoiding his physical presence.
- 30.1.3. The CCTV System shall be fed by the UPS system.
- 30.1.4. All materials and equipment, including accessories and installation items should be appropriated for its operation on offshore environment and in case of external installation appropriated IP grade protection and EX protection shall be applied
- 30.1.5. All cameras and its infrastructure installed in outdoor areas shall be housed in EX-d (explosion proof type) and Zone 1 classification area casing to enable the CCTV system to continue operation in emergency level ESD-3.
- 30.1.6. EX items shall comply with "portaria 115/2022 - INMETRO".
- 30.1.7. CCTV system shall use FPSO IP network infrastructure whenever possible avoiding extra equipment and cable installations.
- 30.1.8. All internal equipment shall be installed in 19" rack space.



30.2. CCTV ARCHITECTURE AND TECHNICAL CHARACTERISTICS

- 30.2.1. It shall be provided 02 (two) servers for the Genetec Security Center platform, so that all equipment used to compose the solution (cameras, recorders, all necessary licenses and others) must be fully compatible with the platform adopted and recognized by the support and maintenance of the manufacturer's software.
- 30.2.2. For the system based on the Genetec Security Center software platform, a system with all necessary licenses must be provided to perform the functions of management system, integration with the AD (Active Directory) of BUYER, Federation of the system location of the vessel with BUYER onshore system and other licenses that are necessary to connect users, view and record the images of the FPSO's cameras
- 30.2.3. For the system based on the Genetec Security Center software platform, the system shall be provided in a redundancy configuration so that in the event of a failure of the management system another unit can assume the function of this unit, avoiding the CCTV system becomes inoperative. The management system can run on the same server as the NVR function.
- 30.2.4. Capacity for at least 20 simultaneous user connections.

30.3. NVR (Network Video Recorder) CHARACTERISTICS

- 30.3.1. It shall be provided 2 (two) NRV equipment with redundancy so that in the event of failure of one unit, the other one can assume.
- 30.3.2. It shall be designed to store all recording videos from the total number of cameras used in the system to be deployed under the following conditions:
- Retention of recorded images for a minimum period of 30 consecutive days
 - Recording at minimum Full HD resolution (1920 x 1080p.)
 - Recording at a rate of 10 FPS (frames per second)
 - Continuous recording (24 hours per day x 7 days per week)
 - Implementation of at least RAID 5

30.4. CAMERAS GENERAL CHARACTERISTICS

- 30.4.1. H.264 or H.265 codification
- 30.4.2. WDR support, white compensation and day & night operation;
- 30.4.3. Lenses with autofocus and auto iris.
- 30.4.4. They must be compatible with the respective VMS software in their native protocol and through the ONVIF Profile S protocol.
- 30.4.5. Minimum resolution in Full HD (1920 x 1080p.) At 30 fps.
- 30.4.6. Support two configurable independent streams profiles and support two configurable ONVIF independent streams profiles;
- 30.4.7. IP Address Filter function or password protection for Web viewing

30.5. SPECIFIC CHARACTERISTICS PER CAMERA TYPE

30.5.1. Fixed Internal Camera Minidome

- Suitable for indoor use

- b. Varifocal lens with minimum zoom range between 3.8-9mm
- c. Sensitivity 1 lux color, 0.1 lux B & W
- d. Automatic Day & Night Operation
- e. Infrared LED with minimum range of 10m and automatic intensity adjustment.

30.5.2. Explosion-Proof External Fixed Camera

- a. Suitable for outdoor use in saline environment
- b. Varifocal lens with minimum zoom range between 5.0 and 80mm
- c. Sensitivity 0.8 lux color, 0.1 lux B & W
- d. Automatic Day & Night Operation
- e. Operating temperature -20 ° C to + 55 ° C
- f. Cleaner and Connection for Water Pump Assembly
- g. Minimum protection; IP 66.

30.5.3. External PTZ Mobile Camera Explosion Proof

- a. Suitable for outdoor use in saline environment
- b. Varifocal lens with minimum zoom range between 5.0 and 80mm
- c. Sensitivity 0.8 lux in color, 0.1 lux B & W
- d. Automatic Day & Night Operation
- e. Operating temperature -20 ° C to + 55 ° C
- f. Cleaner and Connection for Water Pump Assembly
- g. Minimum protection; IP 66
- h. Pan - Tilt: 360 ° and ± 90 °
- i. Presets: minimum 32

30.5.4. Thermal cameras

- a. Thermal cameras shall be provided to monitor possible oil spills to the sea and shall be located to maximize coverage area and include possible spill scenarios from risers.
- b. The riser connection deck shall be monitored by at least 04 (four) dedicated thermal cameras.
- c. At least one thermal camera shall be provided to monitor the offloading operation (oil transfer to shuttle tankers) at each offloading station.
- d. Monitoring shall be based on cameras with thermal vision capacity in the LWIR - 8um a 13,5um minimum range and resolution of 640x480 pixels.

30.5.5. Water Pump / Reservoir Assembly

- 30.5.5.1. In the case of external cameras, fixed or mobile, they must have mechanisms/devices for cleaning the lenses. In case of use of water pump assembly, they must have at least the following specifications:
 - a. Cleaner: Compatible with the camera

- b. Minimum pressure: 4 bar
- c. Capacity of the Reservoir: 5 to 10 liters
- d. Set with all necessary accessories for operation, including hose (20 m) and sprinkler.

30.5.5.2. The assembly shall be suitable for the intended installation environment and provided with the respective accessories for connection to the camera (pump kit).

30.6. Cameras Locations

30.6.1. It shall be foreseen the quantity of cameras distributed around in the areas as table below:

| Area | PTZ – Camera | Fixed Camera |
|----------------------|--------------|--------------|
| Topsides | 50 | 20 |
| Machinery room | 12 | 10 |
| Accommodation Module | 04 | 50 |
| Main Deck | 15 | 10 |

30.6.2. Thermal cameras

It shall be provided at least 01 (one) thermal camera for the following locations:

- a. 01 (one) in each offloading station for oil transfer to shuttle tankers
- b. 04 (four) distributed in the balcony riser
- c. 01 (one) in each room with inert gas generator
- d. 01 (one) in each vent post

30.6.3. The final location will be defined during the detail project.

30.7. Data Switch

30.7.1. The Data Switch purpose is the interconnection of all cameras to the Digital Video Multiplexer, as well as the interconnection of the CCTV system to the corporate network. A Giga Ethernet TCP/IP switch shall be used.

30.7.2. The data switch shall have the following characteristics/features:

- a. Following the electrical access switch specifications.
- b. At least 48 ports 1000 Mbps.
- c. At least 20 % spare ports.
- d. At least 1 (one) interface of 1 Gbps multimode fiber optic port.
- e. Multicasting.

30.8. Monitoring stations

30.8.1. Workstations with CPU and memory capacity in accordance with VMS /system adopted, considering at least 6 H.265 coded images per monitor. The workstations must have at least 2(two) video monitor output.

30.8.2. The monitors shall have at least 24" size with 1280 x 960 pixels minimal resolution.

30.8.3. It shall be provided the workstation + monitor in the following locations:

- a. 02 (two) in the CCR with 01 (one) monitor of 24" and 01 (one) TV OLED – 46" each.
- b. 01 (one) in the radio room with 01 (one) monitor of 24"
- c. 01 (one) in the coordinator's room with 01 (one) OLED TV 46"
- d. 01 (one) in the Safety's room with 01 (one) OLED TV 46"
- e. 01 (one) in the operator's room located in the topside with 01 (one) OLED TV 46"

31. TOOLS AND INSTRUMENTS

It shall be supplied the tools and instruments described below in order to support the maintenance services.

31.1. Certifier and Cable Analyzer

01(one) instrument Certifier and Cable Analyzer DTX-1800-M, manufactured by Fluke with Test module for Multimode Fiber and test Adapter for Cat 6.

31.2. Link Runner

01 (one) Link Runner G2 Kit + inductive Microprobe for cables identification, manufactured by NETSCOUT.

31.3. Wireless Network Analyzer

01 (one) Wireless Network Analyzer, Aircheck G2 manufactured by NETSCOUT, with accessories.

31.4. Microwave Transmission Line and Antenna Analyzer

01 (one) ANRITSU Cell Master Microwave Transmission Line and Antenna Analyzer, Model S810D – 2MHz to 10,5GHz, with accessories.

31.5. Wattmeter

01 (one) wattmeter manufactured by Bird, with the following tablets:

- a. 100 to 250 KHz /50 Watts;
- b. 250 to 500 KHz / 50 Watts;
- c. 2 to 30 MHZ /25 Watts;
- d. 2 to 30 MHZ /250 Watts;
- e. 100 to 250 MHz / 5 Watts;
- f. 100 to 250 MHz / 25 Watts;
- g. 100 to 250 MHz / 50 Watts;
- h. 250 to 500 MHz / 5 Watts;
- i. 250 to 500 MHz / 25 Watts;
- j. 250 to 500 MHz / 50 Watts.

31.6. Wattmeter for digital radios

01 (one) wattmeter for digital radios, manufactured by Bird, with the following tablets:

- a. 250 to 500 MHz / 1 Watts;

- b. 250 to 500 MHz / 5 Watts;
- c. 250 to 500 MHz / 25 Watts;
- d. 1400 to 1600 MHz / 1 Watts;
- e. 1400 to 1600 MHz / 5 Watts.

31.7. RF Coaxial Termination

01 (one) Bird, model 50-T-MN, RF Coaxial Termination of 50 Ohms/50 W with Nconnector.

31.8. Digital multimeter

01 (one) Fluke digital multimeter, model Fluke 28II Ex True-rms, with accessories;

31.9. Impedance meter

01 (one) impedance meter for PAGA system.

31.10. Decibel Meter

01 (one) sound pressure level (SPL) meter type 2/ class 2

- a. Measuring range: 30 ... 130 dB
- b. Resolution: 0.1 dB
- c. Accuracy: ± 1 dB
- d. Frequency: 20 Hz ... 12.5 kHz
- e. Frequency weighting: A, C,
- f. Memory: Stores up to 100 groups with measuring conditions.

31.11. Notebook

It shall be supplied 01 (one) notebook with the minimum configuration below:

- a. Processor (CPU): Intel Core i9- 13900KS, released in the last 18 months or better latest generation (or equivalent)
- b. Operating System: Microsoft Windows 11 professional x64;
- c. RAM memory: 16GB DDR4
- d. Storage: 512 GB internal Solid State Drive (SSD)
- e. Video card with 2GB GDDR5 graphics memory
- f. Network adapter: 802.11ac 2.4/5 GHz wireless adaptor
- g. Monitor: 14" LCD monitor;
- h. I/O Ports: 01 Audio in/out and Microphone Port; 01 VGA; 01 HDMI; 02 USB; 01 Network Port, Webcam and mouse.

31.12. TOOL KITS

- a. 01 (one) tool kit composed by the following items:
- b. Screwdriver 3 x 100mm
- c. Screwdriver 6 x 150mm
- d. Screwdriver 8 x 150mm
- e. Screwdriver Philips 4.5 x 100mm
- f. Screwdriver Philips 6 x 150mm

- g. Screwdriver Philips 8 x 150mm
- h. Screwdriver Philips 4.5 x 38mm
- i. Screwdriver Philips 6 x 38mm
- j. Screwdriver Watchmaker Type Kit
- k. Screwdriver Watchmaker Philips Type Kit
- l. Universal Pliers 8"
- m. Cutters Diagonal Type 4"
- n. Cutters Diagonal Type 6"
- o. Flat Nose Pliers 6"
- p. Flat Nose Pliers 7.5"
- q. Wire Strippers RJ11 & RJ45
- r. Tool for insertion push-down type for 110 IDC connection,
- s. Soldering Iron 110 V 30 W
- t. Tape Measure
- u. Wire Stripper Pliers
- v. Allen Wrench Set
- w. Adjustable Wrench 6"
- x. Adjustable Wrench 10"
- y. Toolbox
- z. Padlock
- aa. 01 Electric screwdriver cordless with accessories
- bb. Set wrench combination with 9 pcs in kit bag 9 (3/8" to 7/8")
- cc. Kit socket (16 pcs)
- dd. Drilling machine with drill unit kit

32. CABLES

- 32.1. All cables specified for critical and safety applications shall be Fire resistant complying with the IEC 60331, Otherwise flame retardant cables complying with IEC 60332 shall be used.
- 32.2. All cables shall be Low smoke emission and zero halogen (LSZH) and minimum of flame retardant complying with IEC 60332.

33. TELECOM SHUTDOWN SYSTEM

- 33.1. According to IEC 60079-0, all radio transmission in outdoor areas that needs to kept in operation during ESD-3, shall be restricted to a safe level of 6 watts, otherwise it shall be turned off.
- 33.2. In order to meet the requirements of IEC 60079-0, a telecommunication shutdown system shall be provided to prevent ignition when flammable gases are leaked into the Unit.
- 33.3. This system shall be able to turn off all radio transmission over 6 watts.
- 33.4. It shall be acceptable gas detector installation in the antenna deck to turn off the radios only after local gas detector.
- 33.5. Additionally, all equipment required to continue in operation, located in classified hazardous areas, during an ESD-3 shall be certified for Zone-1 installation.



34. LTE (LONG TERM EVOLUTION) SYSTEM

- 34.1. SELLER shall provide, install and configure a LTE private network, according to Brazilian Telecom Regulatory Agency rules for private companies, considering the correct frequency ranges and channels for that purpose.
- 34.2. To ensure the compatibility of the LTE equipment with the existing network, the BUYER will inform during the detailed design which manufacturer and model shall be supplied.
- 34.3. The LTE system shall cover the entire outdoor area of the FPSO twice with two cells from two eNodeBs with its outdoor units and irradiating systems installed as far as possible.
- 34.4. The LTE network must also provide indoor coverage including the machinery room and the Central Control Room, considering additional sectors/cell for areas not covered by the main sector.
- 34.5. All irradiating devices at outdoor areas shall comply with IEC 60079-0 9 item 6.6 and CLC/TR50427.
- 34.6. The LTE system shall comply with, at least, release 13 of 3GPP.
- 34.7. The LTE system shall be composed, at least, by:
- 34.7.1. One mini-core to manage the eNodeB's and all the devices onboard;
- 34.7.2. The system can be a full-indoor solution, with only passive antennas at the outside area; or split in two parts, one indoor and the other outdoor. However, if the outdoor module is needed, it shall be suitable for Zone 1 hazardous area.
- 34.7.3. The system shall coordinate the eNodeBs to manage the portable devices at the cell edge, using ICIC (inter-Cell Interference Coordination) or eICIC for frequency reuse 1 (to maximize spectrum efficiency)
- 34.7.4. Antennas distributed along the FPSO to guarantee redundant coverage without shadow areas for real-time video streaming from at least two simultaneous sources in Standard Definition (720 x 480) at the same position; or upload transmission rates always higher than 3 Mbps and download rates higher than 5 Mbps.
- 34.7.5. Hardware/software for dispatch console able to manage and control each device; receive video streaming and export them to screen at the Central Control Room and also to a recording system, or integrated with the recording device of the CCTV system. This solution shall be able to divide the communication devices into at least 15 groups of interest for conversation in Push-To-Talk mode, where one voice dispatch inside one group is heard at all other devices of the same group. From the BUYER software at the Central Control Room, it shall be possible to broadcast voice messages to all groups.
- 34.8. The LTE mini-core onboard shall be integrated with the operator's LAN (Local Area Network), allowing dataflow exchange between the LTE infrastructure and the IP network of the FPSO.
- 34.9. The LTE system onboard shall be able to be managed and configured remotely from shore through the WAN (Wide Area Network) that supports FPSO's communication.
- 34.10. All licenses, certificates, databooks and passwords shall be delivered to BUYER to have all information to operate the system.

35. ANTENNAS

- 35.1. In order to avoid the galvanic corrosion all outdoor antennas, exposed a marine atmosphere, shall be isolated of the ship structure.

36. SELLER TELECOMMUNICATION SYSTEM

36.1. During the operation period by SELLER, it shall have its own voice and data communication systems for all its personnel onboard, including the communication with the onshore site.

37. DETAILED DESIGN DOCUMENTATION

37.1. The following documents shall be sent to BUYER comments and approval during the project:

37.1.1. Block diagrams and online diagrams:

- a. VSAT system
- b. Structured Cabling Network
- c. Videoconference system
- d. (-) 48 VDC power system
- e. racks arrangement
- f. GMDSS system
- g. Operational Radio System
- h. ETEX - M
- i. UHF Active Repeater System
- j. IPTV system
- k. PAGA system
- l. Telecommunications Power System
- m. Data equipment interconnection
- n. WLAN system

37.1.2. General Arrangement:

- a. Radio room
- b. CCR
- c. Telecommunications equipment room
- d. Antenna deck lay-out
- e. Accommodations
- f. Battery room
- g. Structured Cabling Network;
- h. PAGA
- i. TVRO

37.1.3. Additional documents

- a. Cable routing for UHF active repeater network
- b. Approval certification of PAGA System form Classification Society
- c. Certification report for Structured Cabling Network
- d. Pre-commissioning procedure and report for BUYER VSAT.
- e. Calculation report for UHF Active Repeater System
- f. Calculation report for PAGA System
- g. Calculation report for WLAN System



- h. Calculation report for TVRO System
- i. Calculation report for Telecom Power System
- j. Table with all data equipment information, as: manufacturer, model, serial number and MAC address

37.1.4. SELLER shall deliver to BUYER a book with all as built documents related to telecomms systems.

38. CRANE TELECOMMUNICATIONS REQUIRMENTS

- 38.1. Each crane shall have 01 (one) non DCS VHF maritime base station with foot PTT and headphone.
- k. The radio equipment supplied shall be homologated by ANATEL.
 - l. SELLER shall be responsible for issue all documents in order to legalize the system according to Brazilian legislation.
- 38.2. Each crane shall have one loudspeaker from PAGA system A and B.
- 38.3. Each crane shall have a telephone extension from the telephony system.
- 38.4. Each crane shall have a camera to record and monitoring the load operations.
- a. These cameras shall be integrated in the FPSO CCTV system

39. TELECOM TOWER

- 39.1. A telecommunications tower with sufficient height must be located on top of the accommodation to ensure the appropriate location of omnidirectional antennas, meteorological sensors and GPS antennas, thus avoiding clutter or shadow areas caused by the topside modules.

40. E-POB SYSTEM

- 40.1. It shall be supply, install and commissioning the ePoB system based on Bluetooth Low Energy (BLE) beacons and TAGs to be used for location and tracking of people in FPSO.
- 40.2. The e-PoB System shall be considered as a critical system to support people attendance confirmation at muster stations and to easily find people on board during real or simulated emergency situations.
- 40.3. The e-PoB system must cover the entire FPSO including all accommodation areas, antenna deck, engine room, offices, workshops, recreation rooms, main deck, forecastle and topside modules to ensure that it is possible to identify the location from anyone carrying a TAG throughout the FPSO. The system shall be duplicated and installed in different locations: Telecom Equipment Room and other room located in different deck.
- 40.4. The e-PoB system shall be powered by both UPS bus bar.
- 40.5. The e-PoB system shall use Bluetooth Low Energy (BLE) technology.
- 40.6. The Bluetooth standard to allow communication between the BLE TAG (portable) and the BLE beacons (fixed) shall be 5.0 or higher, according to System Vendor.



- 40.7. All transmitter radios and appliances, if applicable, shall be certified in accordance with ANATEL Standards and CONTRACTOR shall provide all necessaries licenses to regular operation in Brazil.
- 40.8. The BLE beacons can communicate between them using Bluetooth Mesh SIG standard.
- 40.9. The BLE beacons can also communicate through the Wi-Fi network for a more accurate localization.
- 40.10. PETROBRAS Wi-Fi system can also be used to complete POB solution. In this case SELLER will be responsible to supply all additional licenses needed in the WLAN devices to capable the interface with e-PoB system.
- 40.11. The BLE beacons that will be powered by batteries shall present autonomy for 3 years, considering a 2s time transmission cycle. The battery status shall be monitored remotely, and alarms shall be sent warning when the battery achieves 20% of its autonomy and keep warning at each 5% lower than 20%.
- 40.12. The BLE Infrastructure shall be composed, at least, by:
- BLE beacons (standalone devices)
 - BLE TAGs (portable TAGs)
 - Softwares of management, visualization and configuration.
- 40.13. In each indoor muster point, it shall be provided a 32 inches TV monitor straight connected to both POB systems (A and B) by means of a KVM device. Such monitor must present the list of all people supposed to be at that muster point with a clear indication of the absent or attended ones.
- 40.14. In each outdoor muster point, it shall be provided any small screen viewer (tablet) with the total of people absent or attended at that muster point. Such small screen (tablet) must be proper for harsh environments and be installed inside the appropriated box, according to classification area.
- 40.15. It shall be provided and installed 01 (one) dedicated HMI workstation (with mouse, keyboard and 24 inches monitor) straight connected to both POB systems (A and B) at the following rooms:
- SELLER representative office
 - CCR
 - Helideck reception desk office
- 40.16. TV monitors, KVMs and small screens shall also be powered from Unit's UPS power and from circuit breakers inside the closer POB cabinet available.
- 40.17. It shall be supplied 500 (five hundred) BLE TAGs in a tag shape, complying with hazardous areas zone 1 (EPL Gb) compatible with the BLE beacons.
- 40.18. It shall be supplied BLE beacons in a number to cover the whole Unit.
- 41. TEMPORARY INTERNET SERVICE**
- 41.1. During Shipyard Commissioning, SELLER shall supply a temporary internet service exclusive for BUYER onboard the FPSO, with the following requirements:
- 01 (one) fixed public IP address.



TITLE:

TELECOM MASTER SPECIFICATIONS FOR BOT UNITS

- b. Availability must be equal to or greater than 99.50%, measured over a period of one month.
 - c. The Service provider cannot be submitted to any kind of restriction or control, in such a way that encrypted data is not impacted and VPN tunnels can be established with no issues.
 - d. Bandwidth requirement: 1Gbps of downlink and a minimum of 10% for uplink.
 - e. The link shall be connected to a 10/100/1000BaseTX interface of BUYER SDWAN firewall inside BUYER WAN rack.
- 41.2. The interconnection of this circuit between the shipyard's administrative building and the FPSO shall be via optical fiber, to ensure a free obstruction such as other vessels and service cranes.